

Optical Fouling Monitors

Dr RL Wetegrove, Dr RH Banks

III General Meeting - Biocorrosion Network

Workshop on Monitoring Systems

Venezia 12-14 April 2000

Nalco Optical Monitors

- Five Patents:
 - Disk Monitors
 - Reflectance (US 5,264,917)
 - Transmittance (US 5,155,555) Paper
 - Wiper Monitor (US 5,185,533) Cooling Water
 - Falling Stream (US 6,023,070)
 - Living Deposits Detection (US 5,796,478)
- One Standardized, One in Development

Disk OFM in Read Position

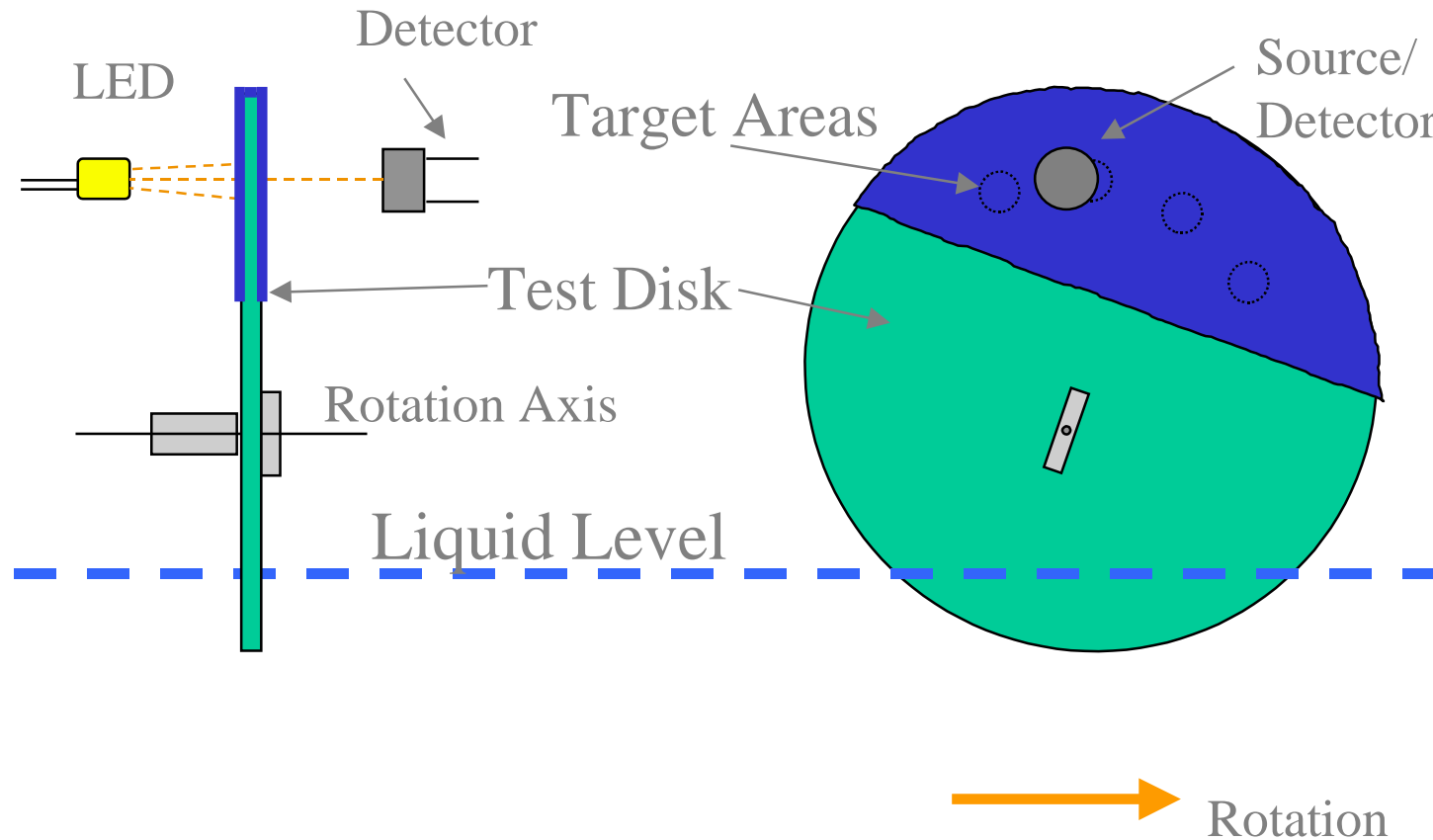

Disk OFM Application Example

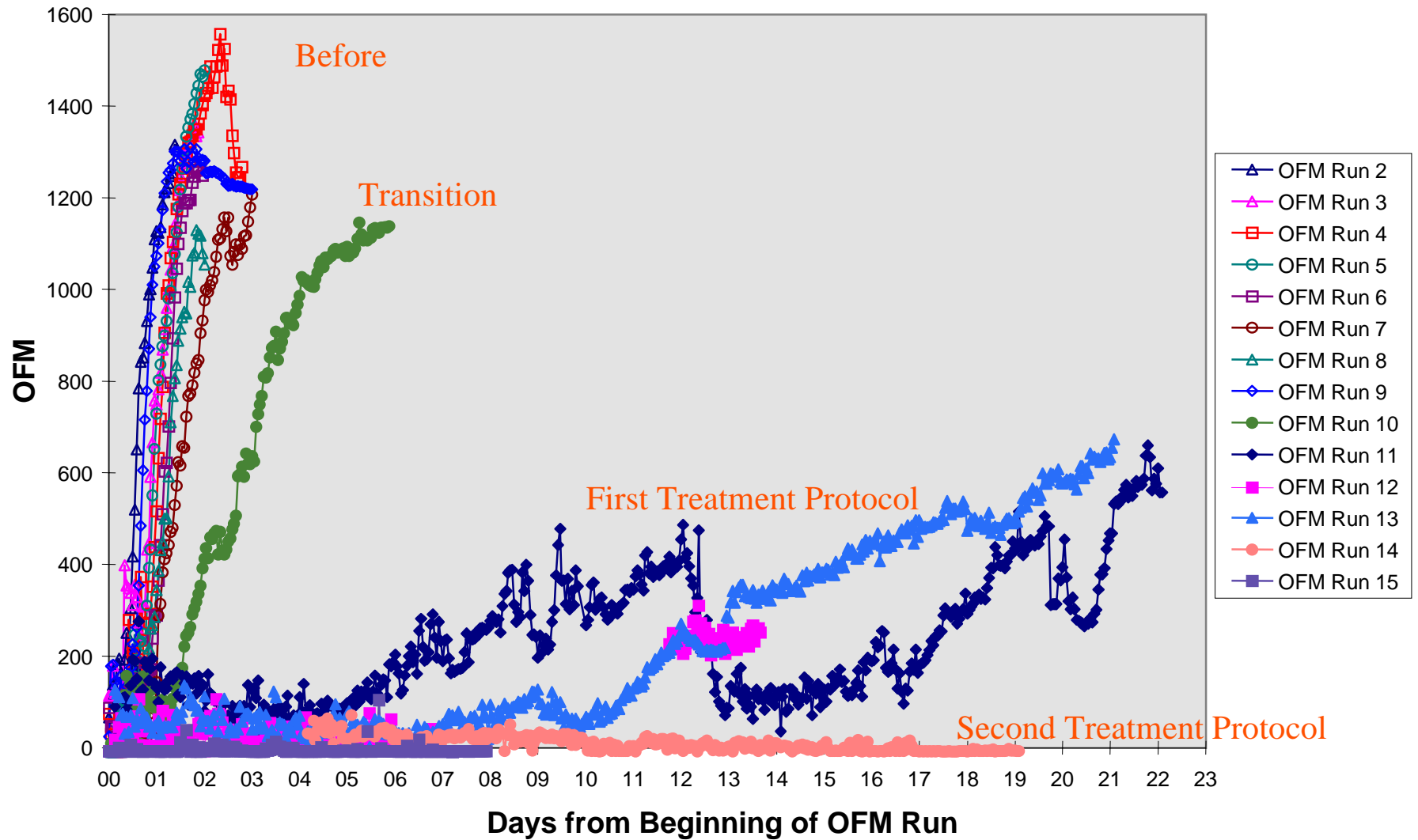

Falling Stream OFM

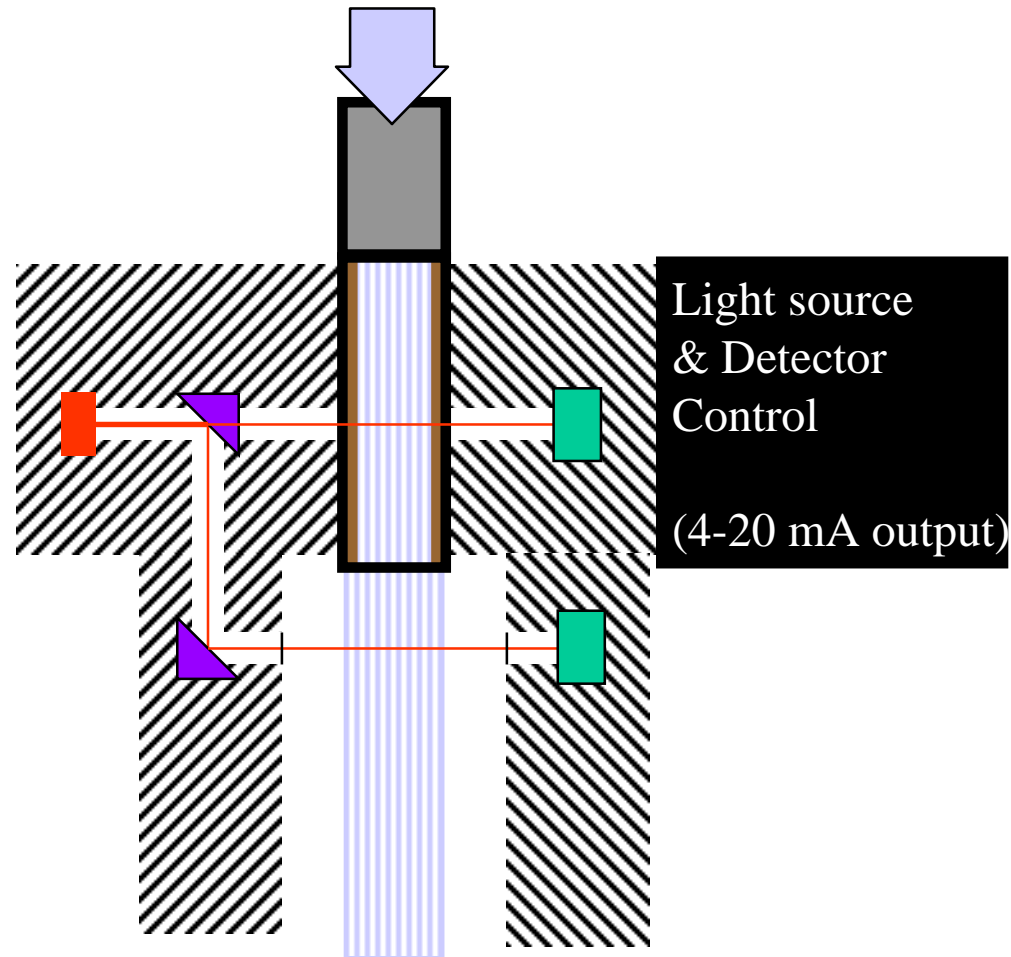

Nalco Falling Stream Monitor Results

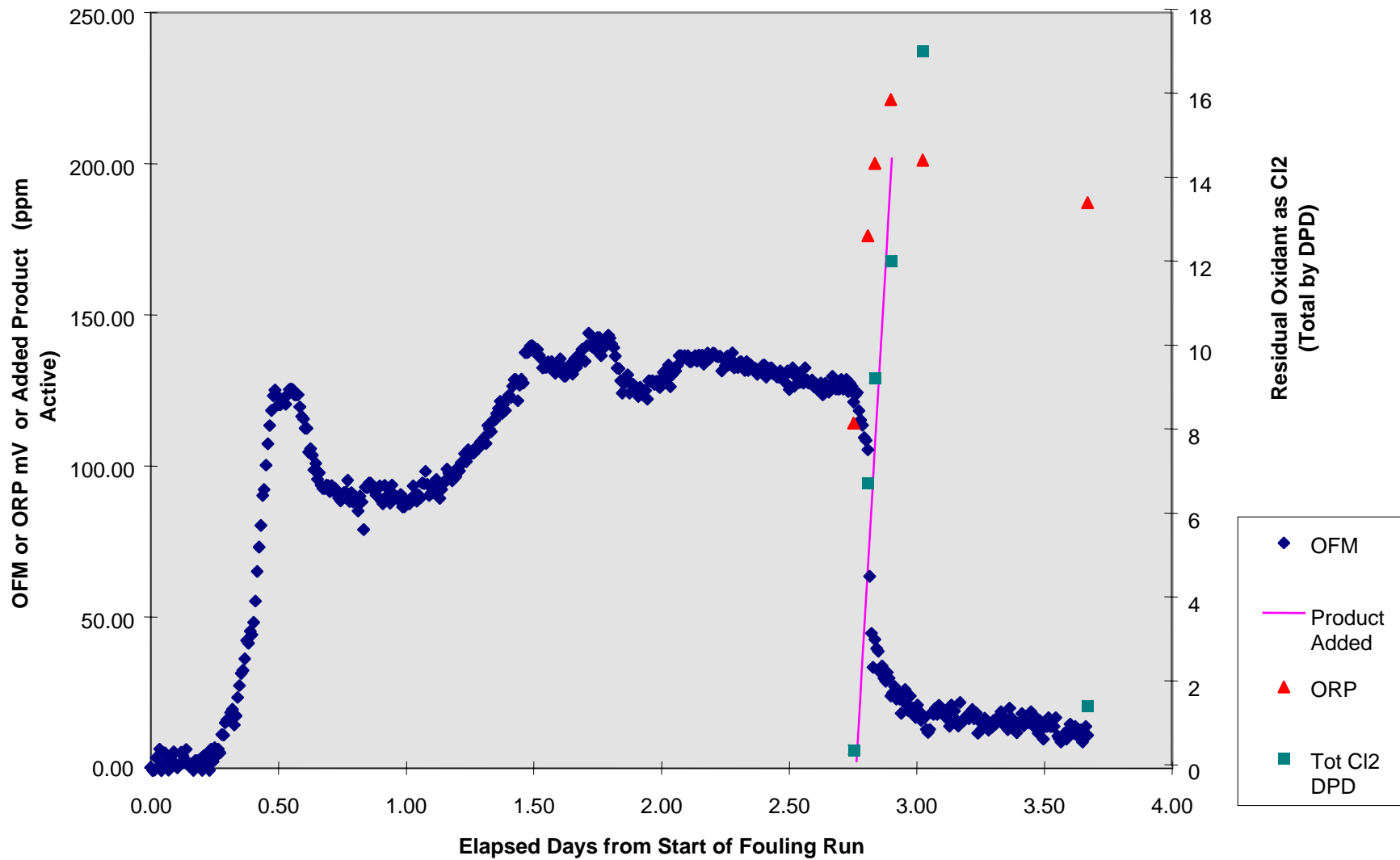

Wiper OFM

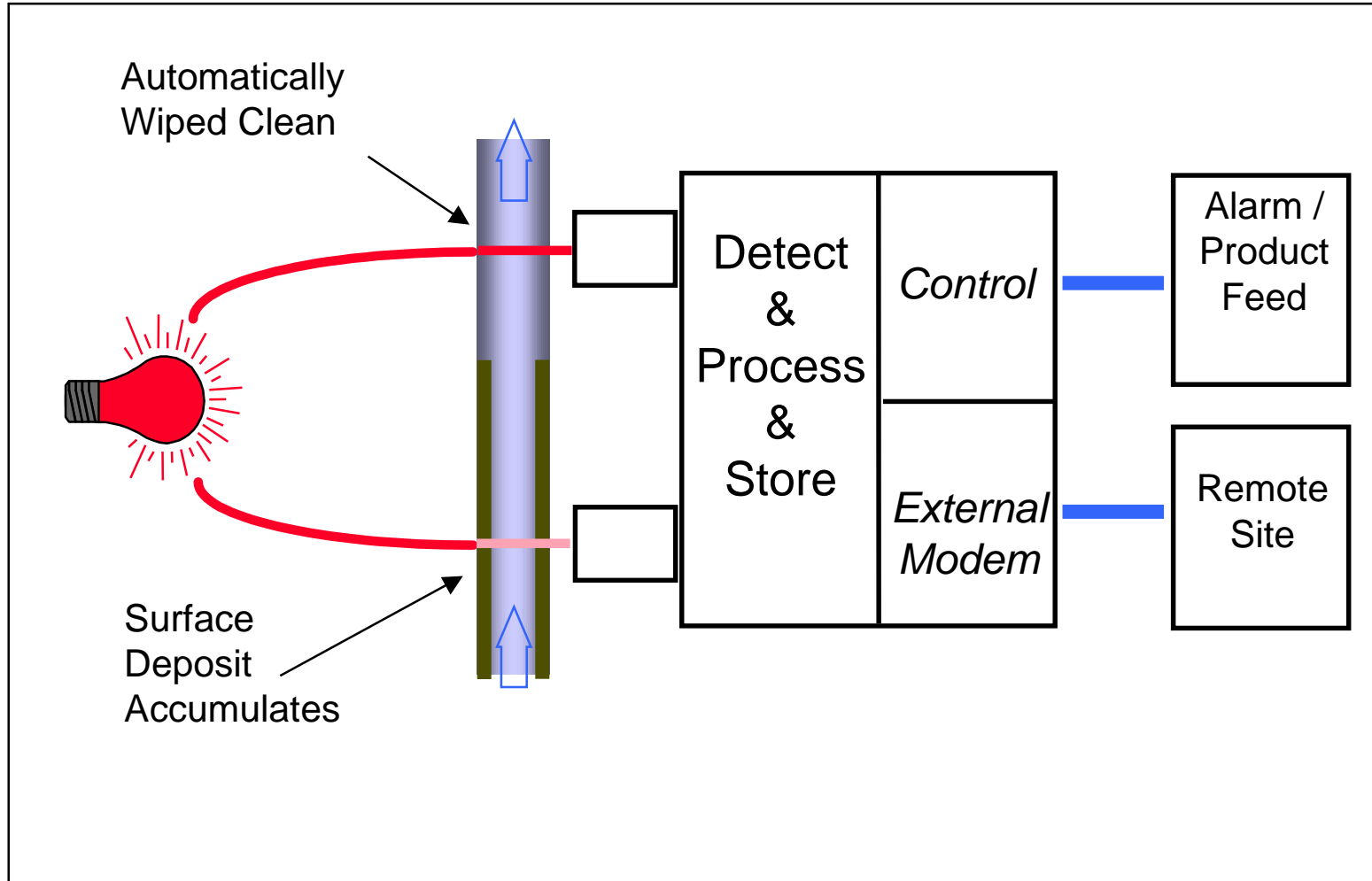

ORP & Fouling Monitors -- March to June

