

NEWSLETTER

It's the members of the EFC that make it what it is

Welcome to the latest edition of the EFC Newsletter. There are many highly relevant and interesting articles for you to read, reflecting the ever-increasing breadth and reach of EFC activities, so I trust you will all find something of particular interest in these pages. I'd like to take this opportunity to thank our editor, Dan Mobbs, for his continued efforts to enhance the newsletter and include even more high quality content from our valued Member Societies, Affiliate Members and Working Parties.

The EFC is a strong community and it was great to witness this at first hand at EUROCORR 2025 in Stavanger. I note that in the previous edition of the Newsletter, conference chair Torfinn Havn had noted that over 900 delegates would be gathering for the event. In the end, we had more than 1,200 attendees, exceeding everyone's expectations! There was a real buzz around the conference all week and massive credit goes to Torfinn, Line, and the rest of the team for their fantastic work in the lead up to and during the event.

I was pleased to see that the quality of the talks presented at EUROCORR was as high as ever, reinforcing its status as one of the world's leading scientific conferences on corrosion. It remains a high priority for the EFC to maintain and improve this standard. As conference chair for EUROCORR 2026 in Dublin, I'm excited about the opportunity to build on the success of the Stavanger event!

The EUROCORR conference series continues to break new ground, with the recent announcement that Slovenia will host the event for the first time in 2028. The conference will take place at the Ljubljana Exhibition and Congress Centre in September 2028 (exact dates tbc) with a theme of *Shaping the Future Through Corrosion Under Control*.

As we approach the end of 2025, we acknowledge five members of the EFC Board of Administrators (BoA) who will be stepping down at the end of their terms. I would like to express my sincere gratitude to Claude Duret-Thual, Lorenzo Fedrizzi, Bartłomiej Guzik, Milan Kouril, and Johan Tidblad for all their hard work and dedication during their time on the board; their efforts have been much appreciated.

We welcome a new BoA at the start of 2026. It's a sign of the growing strength of the EFC that the election at the General Assembly in June was highly over-subscribed, for which I'd like to thank all those who took part and warmly congratulate those who were elected. It's particularly pleasing to note that no fewer than four of the elected BoA members are former Young EFC committee members, highlighting the value that Young EFC is clearly adding to the future of the Federation.

Looking further ahead, we will be holding elections for the positions of Chair and Vice-Chair of all EFC Working Parties at EUROCORR 2026 in Dublin. This is an opportunity for you to volunteer to play a coordinating role in the activities of your scientific peers, raise your profile within your field, and give something back to the community. It's also vital for the health of the EFC and EUROCORR that Working Party topics and their leadership are regularly reviewed and refreshed where appropriate. I would like to commend the valuable work that our Science & Technology Advisory Committee (STAC) Chair, Stefan Ritter, has been doing in this regard.

Finally, with the holiday season approaching I'd like to wish each and every one of you a well-deserved and enjoyable break. I look forward to seeing what 2026 will bring!

Gareth Hinds
EFC President

INSIDE THE NOVEMBER EFC NEWSLETTER

[2. ALL EYES ON DUBLIN AND EUROCORR 2026](#)

Topics, plenary speakers, and Summer School announced

[4. EFC SUMMER SCHOOL](#)

Read the first details of the event planned in Dublin

[6. THREE CHEERS FOR STAVANGER](#)

Snapshots of the successful four-day conference

[9. AWARD WINNERS](#)

EUROCORR was the setting to honour some of EFC's best

[12. YOUNG EFC](#)

A change of Chair and a busy EUROCORR for the YEFC

[16. WORKING PARTY AND TASK FORCE ROUND-UP](#)

WP 4 lead tributes and award prestigious honour

[23. EFC BOARD MEMBER WINS PRESTIGIOUS PRIZE](#)

Herman Terryn receives the U R Evans Award

[25. MEMBER SOCIETIES AND AFFILIATE MEMBERS](#)

The latest news and info

[40. EFC EVENTS](#)

Make a date in your calendar for the latest EFC events

Preparations for EUROCORR 2026 begin in earnest

Céad míle fáilte! (A hundred thousand welcomes!) from the organising committee of the European Corrosion Congress, which will be held from 6 to 10 September 2026 in Dublin



Wikimedia Commons / AnaRay

The Convention Centre Dublin will host EUROCORR 2026 next year from 6 to 10 September, where over 1,000 are expected to attend Europe's largest corrosion conference

Co-hosts, the Institute of Materials, Minerals & Mining (IOM3) and the Institute of Corrosion (ICorr) have announced details of Europe's largest corrosion conference, which next year will be held at The Convention Centre Dublin, Ireland.

The cosmopolitan Irish capital has a vibrant, unique and colourful personality that will provide an exciting base for the CPD-accredited conference, which is expected to attract upwards of 1,000 delegates.

EUROCORR 2026 is a flagship event in the international corrosion calendar and will explore all aspects of corrosion science, technology, and engineering, with a focus on the main theme: *Investing in our future: corrosion challenges for green technologies*.

Call for Papers

The call for papers is now open and the available topics and sessions are listed on the next page. Please prepare your abstract as a PDF (maximum one page and 1 MB file size using [this template](#); see also the [submission information file](#)). The abstract should explicitly mention objectives, results and conclusions and/or significance of the work.

Accepted abstracts will be published for all conference participants as a digital Book of Abstracts (conference proceedings as PDF file) shortly before the commencement of the conference.

Dates for your Diary

→ Deadline for lecture and poster submission - **16 January 2026**

→ Authors confirmation with link to register as a speaker - **April 2026**

→ Registration deadline for authors/early bird deadline- **1 June 2026**

Abstract submission details

The selection of the contributions will be based on the review of the abstracts by the International Scientific Committee. Please note that several prizes will be awarded at EUROCORR, including the EFC Poster Prize, Best Oral Presentation Award, Nuclear Corrosion Oral & Poster Prize, and more. Three presentation options can be selected:

→ Lecture (20 min): Regular oral presentation (15 min talk plus five minutes for Q&A).

→ Poster: "Classical" poster presentation.

→ Short Lecture (five minutes): Short oral presentation (three minute talk with a maximum of four slides including title slide, plus two minutes for Q&A).

Shortly after the EUROCORR conference, a digital Book of Presentations will also be distributed to all registered conference attendees, containing those presentation files made available by the authors (voluntarily). Technical details for the process will be given to all presenters in due time.

Introducing the plenary speakers

The first plenary speakers have been revealed with more to be announced in due course



Professor Mary Ryan, FEng CBE
Imperial College



Professor En-Hou Han,
Institute of Corrosion Science & Technology, Guangzhou

EUROCORR 2026 Topics

- **WP1: Corrosion and Scale Inhibition**
CHAIR: Prof Kostas Demadis, Greece
- **WP3: High-temperature Corrosion and Degradation**
CHAIR: PD Dr. Mathias GALETZ, Frankfurt, Germany
- **WP4: Nuclear Corrosion**
CHAIR: Stefan RITTER, Villigen, Switzerland
- **WP5: Environment Sensitive Fracture**
CHAIR: Prof. Christine BLANC, Toulouse, France
- **WP6: Surface Science & Mechanisms of Corrosion & Protection**
CHAIR: Dr. Robert LINDSAY, Manchester, United Kingdom
- **WP7: Corrosion Education**
CHAIR: Prof. Dr.-Ing. Daniela ZANDER, Aachen, Germany
- **WP8: Physico-chemical Methods of Corrosion Testing**
CHAIR: Dr. Noémie OTT, St Gallen, Switzerland
- **WP9: Marine Corrosion**
CHAIR: Prof. Philippe REFAIT, La Rochelle, France
- **WP10: Microbial Corrosion**
CHAIR: Dr. Pierangela CRISTIANI, Milan, Italy
- **WP11: Corrosion of Steel in Concrete**
CHAIR: Prof. Dr.-Ing. Michael RAUPACH, Aachen, Germany
- **WP13: Corrosion in Oil and Gas Production**
CHAIR: George WINNING, Egham, United Kingdom
- **WP14: Coatings**
CHAIR: Prof. Marie-Georges OLIVIER, Mons, Belgium
- **WP15: Corrosion in Refining and Petrochemical Industries**
CHAIR: Prof. Dr. Philipp SCHEMPP, Koln, Germany
- **WP16: Cathodic Protection**
CHAIR: Jérôme CROUZILLAC, Voisins-le-Bretonneux, France
- **WP17: Automotive Corrosion**
CHAIR: Elizabeth SZALA, Duffel, Belgium
- **WP18: Tribo-Corrosion**
CHAIR: Dr. Manel RODRIGUEZ RIPOLL, Vienna, Austria
- **WP19: Degradation of Polymer Materials**
CHAIR: Dr.-Ing. Jürgen HEINEMANN, Berlin, Germany
- **WP20: Corrosion in Water Systems**
CHAIR: Dr. Johann Wilhelm ERNING, Berlin, Germany
- **WP21: Corrosion of Archaeological and Historical Artefacts**
CHAIR: Dr. Delphine NEFF, Gif/Yvette, France
- **WP22: Corrosion Control in Aerospace**
CHAIR: Prof. Dr. Mikhail ZHELUDKEVICH, Geesthacht, Germany
- **WP23: Corrosion Reliability of Electronics**
CHAIR: Prof. Dr. Rajan AMBAT, Lyngby, Denmark
- **WP24: CO₂-Corrosion in Industrial Applications**
CHAIR: Dr. Ralph BÄSSLER, Berlin, Germany
- **WP25: Atmospheric Corrosion**
CHAIR: Prof. Johan TIDBLAD, Kista, Sweden
- **WP26: Corrosion in Green & Low Carbon Energy Technologies**
CHAIR: Marc WILMS, Amsterdam, The Netherlands
- **TF: Corrosion of Medical Implants and Devices**
CHAIR: Dr. Patrik SCHMUTZ, Dübendorf, Switzerland
- **TF: Corrosion and Corrosion Protection of Additive Manufactured Metals**
CHAIR: Prof. Iris DE GRAEVE, Brussels, Belgium
- **WP4/WP6/WP8/WP11/WP21: Imaging Corrosion: New Frontiers in Materials**
CHAIRS: Ueli ANGST, Anders KASTNER, Laura BRAMBILLA
- **WP9/WP10: Microbial Corrosion and Biofouling Issues in Marine Environments**
CHAIRS: Philippe REFAIT & Pierangela Cristiani
- **WP9/WP16: Cathodic Protection in Marine Environments**
CHAIRS: Philippe REFAIT & Jerome CROUZILLAC
- **WP18/WP26: Wear & Corrosion in Green Energy Systems**
CHAIRS: Manel RODRIGUEZ RIPOLL & Marc WILMS
- **WP19/WP14: Polymers in Organic Coatings**
CHAIRS: Jürgen HEINEMANN & Marie-Georges OLIVIER
- **WP22/WP17/WP25: Artificial Intelligence Supported Corrosion Tests in Transport Applications**
CHAIRS: Mikhail ZHELUDKEVICH, Elisabeth SZALA & Johan TIDBLAD
- **WP26/WP5: Hydrogen in the Energy Transition**
CHAIRS: Jean KITTEL, Gareth HINDS, Tomas PROSEK, Christine BLANC & Dirk ENGELBERG
- **Joint Task Force: Corrosion and Corrosion Protection of Additive Manufactured Metals for Biomedical Applications**
CHAIRS: Patrik SCHMUTZ and Iris DE GRAEVE
- **67th ICorr Corrosion Science Symposium**
CHAIR: Julian WHARTON, Institute of Corrosion (ICorr)

Dublin to welcome EFC Corrosion Summer School

From Thursday 3 to Saturday 5 September 2026, the Corrosion Summer School will focus on how the energy transition needs more than new ideas – it needs materials that last



Wikimedia Commons/WilliamMurphy

The EFC Summer School 2026 will be held at Technological University Dublin, located in the historic Bolton Street building, right in the heart of Dublin city centre

As society moves toward greener and low-carbon energy systems, corrosion is becoming a hidden bottleneck. Hydrogen technologies, offshore renewables, geothermal plants, and new electrochemical processes expose materials to harsher environments, higher temperatures, and new chemistries.

Durability is no longer just an operational cost question; it determines whether these sustainable technologies can be deployed safely and economically. Understanding corrosion is therefore essential for enabling the energy transition and ensuring that “green” solutions are also reliable and long-lasting.

To support the next generation of corrosion specialists working in this evolving landscape, the EFC is extending invitations to early-career corrosion professionals, PhD students, postdocs, and engineers from industry and academia to attend the EFC Corrosion Summer School 2026 in Dublin.

School Notes

The EFC Summer School 2026 will be held at the Technological University Dublin (TU Dublin), located in the historic Bolton Street building, right in the heart of Dublin city centre. The location offers easy access to cultural sites, authentic pubs, and the EUROCORR 2026 venue.

Intensive and Practical

Held just before EUROCORR 2026, this three-day program offers an intensive and practical introduction to corrosion science and engineering. Participants will benefit from:

- Lectures from leading experts from academia and industry
- A dedicated career development workshop
- Social and networking activities, including lab visits, a pub evening, and sightseeing in Dublin

Save the Date

3–5 September 2026

TU Dublin – Bolton Street

More information on registration, programme details, and fees will be announced soon. Stay tuned via the [EFC](#) and [EUROCORR 2026](#) websites and social media channels.



SEE THE DIFFERENCE

UV Pigment identification.

- ✓ Silver finish
- ✓ Integrated UV tracer
- ✓ COF stability
- ✓ No stick slip
- ✓ No hot loosening
- ✓ Multi-tightening

DAY LIGHT

PLUS® Series

 PFAS-Free

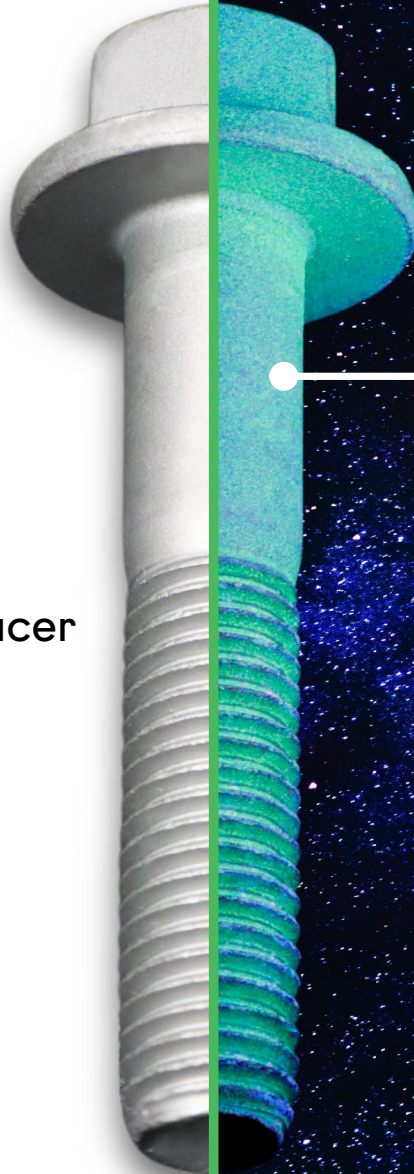

PLUS® VLh 2 Silver

0.09 - 0.14 (ISO 16047)



PLUS® XL 2 Silver

0.06 - 0.09 (ISO.16047)



PLUS® ML 2 Silver

0.10 - 0.16 (ISO 16047)

UV LIGHT

EUROCORR 2025 a big success in Stavanger

The Norwegian Corrosion Society host the latest edition of Europe's largest corrosion conference

One of the largest and most modern conference venues in Norway, The Stavanger Forum, was the venue for EUROCORR 2025, which welcomed over 1,200 attendees from across Europe and the world.

The five day conference brought together corrosion professionals from across the globe, as scientists, researchers, industry experts, and innovators descended on Norway to exchange insights in corrosion science and technology in a friendly and informative space.

Photography by Kristina Maria Lagahino Eriend





Three cheers

Over the course of five days, attendees of EUROCORR 2025 enjoyed a full programme of events in Stavanger, beginning with a Fjord Cruise on Lysefjorden on the opening day, followed by plenary lectures, parallel sessions, the Women in Corrosion Luncheon, before a closing ceremony brought the curtain down on a memorable event.





Photography by Kristina Maria Lagahno Erlund

Passing the baton from one EUROCORR to the next, Torfinn Havn, Chair of EUROCORR 2025 holds the Irish tricolour with Gareth Hinds, Chair of EUROCORR 2026 and EFC President

ADVERTISEMENT

Only Trenton offers Wax-Tape® brand anticorrosion wrap systems, with primers, wraps and outerwraps.



TRENTON
ANTICORROSION MATERIALS
www.trentoncorp.com

EFC award winners honoured at EUROCORR in Stavanger

EUROCORR provided the perfect setting to acknowledge the special contribution of a special group of special corrosionists within the EFC community



Ingrid Milošev (Jožef Stefan Institute, Slovenia) was awarded the 2025 European Corrosion Medal (below, left), and Pascale Bridou Buffet (Fondation de la Maison de la Chimie, France) was made an Honorary Fellow of the EFC (below, right) in Stavanger. Congratulations on the prestigious prizes.





Photography by Kristina Maria Lagahno Erlund



The Next Gen

Jonatan Gomez Granados (top left) (Complutense of Madrid, Madrid, Spain), Klára Kuchtáková (top left) (University of Chemistry and Technology Prague, Prague, Czech Republic), and Marina Furbino Martins (above) (Vrije Universiteit Brussel, Belgium) were awarded the EFC Young Scientist Grant 2025.

The EFC Young Scientist Grant has been presented since 2016 and provides financial support to junior corrosionists to help them to visit and interact with other corrosionists at their home institute abroad.

Arvin Jia Qing Chen (University of Manchester, UK) was presented with the EUROCORR Travel Grant for Young Corrosionists (below). Congratulations Arvin.





The EUROCORR 2025 Poster Prize was presented to Mohammad Ghaderi (Technical University of Denmark (DTU), Denmark) by EFC STAC Chair, Stefan Ritter

Speak Up!

The Best Oral Presentation Awards at EUROCORR 2025 were given to Marlon Mapon (right) (TU Delft, Netherlands) and Federica Ceriani (below) (Politecnico di Milano, Italy)

This year's awardees impressed the audience and the jury with presentations that combined innovative corrosion research and outstanding science communication. Their talks highlighted how clarity, passion, and precision can make research resonate.

A special thank you to Bartek Guzik (right and below) and Mankiewicz, whose continued support makes it possible to recognise and encourage excellence among emerging corrosion scientists.



Photography by Kristina Maria Lagahino-Erland



Federica Ceriani, Politecnico D
"Se... post-treatments of coatings
elect... oxidation (PEO) on AZ31

A new era at the Young EFC beckons with new Chair

After three years of service as Chair of Young EFC, Noémie Ott has announced a successor and Vice-Chair, as well as a new personal challenge within the EFC

The Young EFC is pleased to announce that Johanna Frenck will take over as Chair from Noémie Ott, supported by Kathleen Purnell as Co-Chair.

"After three rewarding years as Chair of the Young EFC. I will be stepping down to continue contributing to the EFC in new ways: as an EFC Board Member and as Chair of WP8," explains outgoing Chair, Noémie Ott. "It is a pleasure to welcome Johanna Frenck (Uni Kassel, Germany) as the incoming Chair of the YEFC and Kathleen Purnell (University of Leeds, UK) as Vice-Chair.

"I first realised the real value of a professional network during my postdoctoral stay in Australia, where the ACA, and its local branch offered numerous opportunities for early-career professionals to connect and grow. When I returned to Europe, I felt strongly about helping to build a similarly supportive and vibrant community for early-career corrosionists – one that complements the long-standing strength of our senior expert network.

"My journey with the YEFC began somewhat by chance in 2021. I had joined the 2020 YEFC meeting simply because it was held online, sparing me to walk into a social event where I did not know anyone. We were only a small group, but I felt an immediate connection with the people and with the YEFC mission. With the encouragement of then-Chair Marta Mohedano, I launched my first initiative – the online career webinar – which eventually grew into a series. Since then, through initiatives like the 3M Plenary Lecture Competition, science communication activities, and career development events, my goal as Chair has been to foster a more diverse, inclusive, and well-connected early-career corrosion community.

"I am deeply grateful for the energy and dedication of the different people involved in the YEFC activities over the years. And I am confident that, under its new leadership, the YEFC will continue to grow, evolve, and flourish."

Join our Community

Welcome to the vibrant world of Young EFC. Their aim is to empower and connect early career professionals in the corrosion and material protection domain beyond traditional boundaries.

So, whether you are an early career corrosionist, budding professional or academic, a seasoned veteran, or simply



young at heart - you are warmly welcome to join the community and activities run over the year! It comprises of people from all levels of ambition and experience.

The best part? Joining the Young EFC is completely free! It is not required that you are already part of the EFC to show interest in the YEFC. Even if you are more advanced in your career and would like to provide support to young professionals in the corrosion field, you are strongly encouraged to express an interest in their activities.

Becoming part of the YEFC community can be simply staying in the loop about our upcoming events, prizes/grants, and promising career prospects, but can also include becoming more involved and joining the YEFC Board that oversees the YEFC activities.

[Click here](#) to find out more.

Meet the Young EFC Board

The YEFC Board consists of **Sajjad Akbarzadeh** (UMons, Belgium), **Arthur Boidot** (NOF Metal Coatings Europe SA, France), **Johanna-Maria Frenck** (Universität Kassel, Germany), **Bartłomiej Guzik** (Mankiewicz Gebr. & Co, Poland), **Ana Kraš** (Jožef Stefan Institute, Slovenia), **Nikola Machácková** (VŠCHT Praha, Czech Republic), **Noémie Ott** (OST, Switzerland), **Kathleen Purnell** (University of Leeds, UK), **Reynier Revilla**

(VUB, Belgium), **Valentina Valbi** (Laboratoire de recherche des monuments historiques, France), **León Zendejas Medina** (KTH Royal Institute of Technology, Sweden), and two new members, **Clara Vestberg** (RISE, Sweden), and **Arshad Yazdanpanah** (University of Padua, Italy). The YEFC Board would like to thank **Mirsajjad Mousavi** and **Can Özkan** for their engagement within the YEFC.



Join the Next Generation of Corrosionists at EUROCORR

If you are an early-career corrosionist, EUROCORR is the perfect place to connect, learn, and be inspired. The Young EFC organises a range of events designed especially for you – from networking sessions and mentoring opportunities to interactive workshops and social gatherings.

Meet peers from around the world, exchange ideas, and take an active role in shaping the future of corrosion science. Do not just attend EUROCORR – be part of the community driving it forward! Here's a few sneak peak of the Young EFC activities at EUROCORR 2025 in Stavanger and what to expect from EUROCORR 2026 in Dublin.

Young EFC Meeting

The Young EFC Meeting once again brought together a vibrant community of early-career corrosion professionals to learn, connect, and share ideas. With over 100 participants, this

annual gathering offered a unique opportunity to discover the YEFC's activities and events running throughout the year.

This year, the YEFC were delighted to welcome representatives from sister societies – Young iCorr and Young GfKorr – who presented their initiatives and ongoing collaborations. The strong engagement and growing attendance highlight the enthusiasm and commitment of young (and young-at-heart) professionals across the corrosion community.

Mingle & Career Fair

The Mingle & Career Fair offered an informal yet inspiring space for networking, complete with drinks and finger food. Participants had the chance to meet peers, exchange experiences, and hear short, insightful presentations from industry experts – talks designed to spark curiosity, share career advice, and fuel ambition.

Women in Corrosion Luncheon - Celebrating voices, sharing stories

The Women in Corrosion Luncheon created a meaningful space for open dialogue and shared reflection. The discussion highlighted that, regardless of background or experience, many professionals in the corrosion community face similar challenges – and that open, honest conversations are key to building understanding and support.

The session was moderated by Noémie Ott, Chair of the Young EFC, and featured insightful contributions from Andressa Trentin, Laura Kahn, Clara Vestberg, Maria Lekka,

and Kristine Myksvoll, who shared their personal experiences and perspectives. Their openness sparked valuable discussions and encouraged participants to consider how we can all contribute to positive change across our field.

The YEFC warmly thanks Mankiewicz for their generous sponsorship and the EFC leadership team for their support in making this important conversation possible. The YEFC looks forward to continuing the dialogue and building on this momentum during the up-coming year and at EUROCORR 2026 in Dublin.



EFC Corrosion Summer School

The EFC Corrosion Summer School - Challenges of corrosion failure analysis, monitoring, and maintenance, was organised by EUROCORR 2025 local organisers, WP7, and YEFC and took place a few days before EUROCORR 2025 at Campus University of Stavanger in Norway.

On Thursday evening the participants enjoyed a relaxed get-together at a local pizzeria and on Saturday morning, a guided tour of the Norwegian Petroleum Museum (Norsk Oljemuseum) in Stavanger Centre.

YEFC Plenary Lecture Competition

Since 2023, the YEFC Plenary Lecture Competition at EUROCORR has showcased the excellence and energy of early-career corrosion scientists. The winner of this year's competition, Livia Cupertino-Malheiros delivered an outstanding plenary lecture on hydrogen embrittlement, captivating the audience with her research on the degradation and sustainability of metal alloys – crucial work supporting the global transition to Net Zero.

The YEFC warmly congratulates Livia for her inspiring contribution and thanks all participants who continue to

elevate the visibility and impact of early career professionals within the corrosion community.

Be the Next YEFC Plenary Lecturer at EUROCORR 2026. The YEFC invites early-career corrosionists to apply for the 3M Plenary Lecture Competition and seize the opportunity to present their work on the EUROCORR 2026 plenary stage in Dublin, Ireland from 6 to 10 September 2026.

[Submit your application](#) by 25 January 2026 and take your research – and your communication skills – to the next level. Details about eligibility and application process can be found [here](#).

Looking Ahead

Missed the excitement this year? Don't worry, as EUROCORR 2026 will be your next opportunity to connect with leading corrosion experts, share your research, and take part in the vibrant scientific community that defines our field.

Stay tuned for more details and start preparing your abstracts early – your work could be among next year's award-winning presentations!

EUROCORR Travel Grant

Want to share your research on one of the biggest stages in corrosion science? Applications for the EUROCORR Travel Grant are open. The grant helps young corrosion researchers and students attend EUROCORR 2026, where they can present your work, network with experts, and exchange ideas that drive the field forward.

EFC Young Scientist Grant

Are you ready to take your corrosion research abroad? The EFC Young Scientist Grant supports a scientific visit abroad. The call for applications is open and closes on 15 February 2026. The grant offers you the chance to collaborate with a senior corrosionist at their home institute. Strengthen your expertise, build lasting collaborations, and explore new scientific perspectives.

Tip: Start now by finding your host institution. Use the EFC Working Party and EFC LinkedIn group to connect with potential hosts within the EFC network.

Deadline for Both Grants: 15 February 2026

Need some inspiration? Curious about what past winners achieved? [Check out](#) last year's EFC Young Scientist and

EUROCORR Travel Grant awardees – and see where their passion for corrosion science has taken them!

YEFC Sponsor

The Young EFC is proud to welcome Dörken Coatings GmbH & Co. KG as their newest Super Sponsor! Their commitment to empowering the next generation of professionals and strengthening cross-industry networks creates invaluable opportunities for young talents to connect, learn, and grow.

DÖRKEN

Support the Next Generation

The Young EFC is seeking sponsors for its upcoming activities, including EUROCORR 2026 and the YEFC Summer School.

Partnering with the Young EFC is a unique opportunity to empower early-career researchers, connect with future leaders, and enhance your organisation's visibility within the corrosion community. For sponsorship opportunities, please contact the YEFC team.

ADVERTISEMENT

 **MONTIPOWER**
Ultimate Surface Preparation

SPOT ON!

THE WORLD'S BEST COATINGS DESERVE THE BEST SURFACE PREPARATION

WWW.MONTIPOWER.COM

PNEUMATIC ATEX - CORDLESS - CORDED - SUBSEA - ROBOTICS



Exciting nuclear corrosion session during EUROCORR

A busy conference for Working Party 4 included keynote speeches, talks, and prizes for the best oral presentation and the best nuclear corrosion-related poster



Sebastian A. Skaanvik (far left) with WP 4's Vice-Chair Laure Martinelli was awarded the prize for the Best Nuclear Corrosion-Related Poster Presentation, while WP 4 Chair, Stefan Ritter, presented Daniel Stein with the Best Oral Presentation prize

This year's Nuclear Corrosion session at EUROCORR opened with an excellent keynote lecture titled *In-Situ Neutron Reflectometry and Electrochemical Impedance Spectroscopy Study of Hydrogen Absorption into Copper, Induced by Corrosion in Bisulphide Solution*, delivered by Jamie Noël from Western University (Ontario, Canada).

In total, 34 high-quality talks and five posters were presented, and many of the talks were followed by lively discussions. The session covered nearly the entire spectrum of nuclear corrosion topics, including corrosion issues in nuclear waste disposal and in future reactor systems, corrosion of fuel cladding materials, flow-accelerated corrosion, environmentally-assisted cracking, and fuel reprocessing.

On Monday afternoon, a second keynote lecture was given by Ingrid Proriol Serre (Lille University, France), this year's winner of the Henry Coriou Award (see the previous edition of the EFC Newsletter).

Perfect Presenters

After the session concluded on Wednesday afternoon, the WP 4 Business Meeting took place, during which all WP 4 activities were presented and planned.

The meeting also included the award ceremony for the WP 4 prizes, recognising the Best Oral Presentation by an Early-Career Presenter and the Best Nuclear Corrosion-Related Poster.

The prize for the Best Oral Presentation by an Early-Career Presenter during the 2025 Nuclear Corrosion session was awarded to Daniel Stein (Belgian Nuclear Research Center SCK CEN, Belgium) for his presentation, *Effect of Dissolved Iron and Nickel on Corrosion Behavior of 316L Austenitic Stainless Steel in Liquid Pb*.

The prize for the Best Nuclear Corrosion-Related Poster presentation was awarded to Sebastian A. Skaanvik (Western University, Ontario, Canada) for the poster *Corrosion of Copper in Nitric Acid: Towards Understanding the Degradation Pathway of Used Fuel Containers*.

Congratulations to both winners and a big thank you to the sponsorship of the prizes by Elsevier, ZAG and EFC. And at EUROCORR 2026 the prizes will be awarded again. Prize rules are available on the [WP 4 website](#).

Also during next year's EUROCORR in Dublin, a Nuclear Corrosion session, as well as a Joint Session on *Imaging Corrosion: New Frontiers in Materials Degradation Research* will be organised. Don't forget to submit your abstract by January 2026.

[Click here](#) to visit the WP 4 website.

WP4
Nuclear Corrosion

Ninth international Workshop supported by Working Party 4

Held in Sendai, Japan, the workshop focused on corrosion challenges related to the long-term storage of nuclear waste and attracted over 80 scientists

The 9th International Workshop on Long-Term Prediction of Corrosion in Nuclear Waste Systems (LTC 2025), held in Sendai, Japan, has just concluded and can be regarded as a great success.

Supported by the Working Party 4 on Nuclear Corrosion, the conference welcomed 87 scientists and engineers from 13 countries who presented and discussed corrosion challenges related to the long-term storage of nuclear waste.

One of the highlights of the event was the Young Researcher Award, sponsored by the EFC. Kwanil Chae (right) from the Seoul National University (Republic of Korea) received the award for his presentation titled, *Growth Behavior of Mechanically-Induced Pits on Copper in Chloride Environments Relevant to Deep Geological Repository (DGR)*.

The workshop concluded with a technical tour to Fukushima Daiichi nuclear power plant. The next edition of the workshop will take place in 2028 in China.

The conference has been a cornerstone event for professionals and researchers since its inception. Over the years, LTC has provided a platform for discussing the latest advancements and challenges in the corrosion behaviour of materials used in nuclear waste storage and disposal facilities.

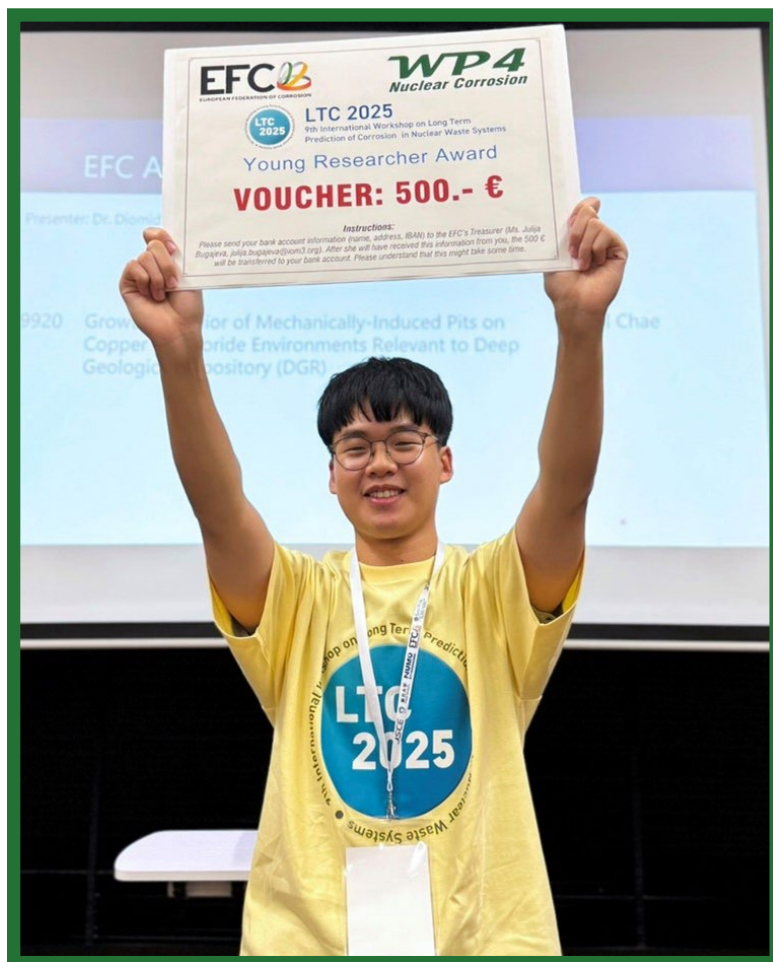

Workshop organised for EUROCORR 2026 participants

The Contribution of AI to Corrosion Research – CAICOR workshop will focus on the design of corrosion-resistant materials using artificial intelligence

This newly established workshop will take place on the afternoon of Thursday 10 September, immediately following the conclusion of EUROCORR 2026. Held at the same venue, it will focus on the design of corrosion-resistant materials using artificial intelligence (AI), as well as the role of AI in data analysis and in corrosion research.

The workshop, titled *Contribution of AI to Corrosion Research – CAICOR* will feature two plenary lectures (40 minutes each) and six additional lectures selected from submitted abstracts. The attendance will be free of charge and the call for abstracts together with further details will be published soon on the [WP 4 website](#).

WP 21 to host webinar Green Book presentation

Join the WP 21 team to explore the interdisciplinary connections essential for advancing the preservation of metallic heritage artefacts

The Working Party 21 on Corrosion of Archaeological and Historical Artefacts will host a webinar on Wednesday 10 December 2025 at 2pm, during which details of the book, *Bridging the Gap: Corrosion Science For Heritage Contexts* will be presented.

Conservators and conservation scientists often train as generalists due to the wide range of heritage objects, especially metals. Yet, preserving and restoring metals requires a fine knowledge of their decay processes in complex environments. This demands for strong collaboration between conservators and specialists like corrosion scientists. How can these connections be fostered, and why is there currently a gap between the professions? [Click here](#) to register your interest

Bridging the Gap

Bridging the Gap: Corrosion Science For Heritage Contexts explores the decision-making processes for preserving heritage metals while also examining the collaborative, interdisciplinary relationships that underpin them. Through

themed chapters, the book is designed to develop and strengthen collaboration between these three groups of professionals, creating a synergy that benefits research and practice for the preservation of heritage metals. It builds an overview of metals conservation across a broad range of heritage contexts, from indoor museum displays to fixed outdoor structures and moving objects.

Researchers and practitioners provide critical insights into corrosion problems within heritage, current corrosion mitigation procedures, and the evidence supporting best practice guidance. The book will be a valuable reference resource for corrosion and corrosion protection scientists, heritage preservation scientists, conservation practitioners, and students studying preservation of cultural objects.

[Click here](#) to buy online.

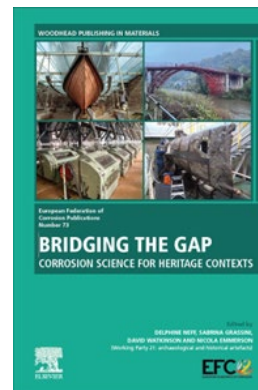

New Working Party 8 Chair team chosen at EUROCORR

Noémie Ott will step down from Young EFC duties to Chair the Working Party 8 on Physico-chemical Methods of Corrosion Testing, with Santiago Garcia Espallargas as VC

At the Working Party 8 Business Meeting at EUROCORR 2025 in Stavanger, a new chairing team was elected.

Noémie Ott (OST, Switzerland) will serve as Chair and Santiago Garcia Espallargas (TU Delft, Netherlands) as Vice-Chair, succeeding Iris De Graeve (VUB, Belgium), who will continue her active role within the Task Force on Corrosion and Corrosion Protection of Additive Manufactured Metals.

Under this new team, the WP 8 on Physico-chemical Methods of Corrosion Testing is broadening its scope to embrace FAIR data principles (Findable, Accessible, Interoperable, Reusable) alongside its strong foundation in metrology, method development, and correlative corrosion testing.



The Working Party will continue to foster collaboration across academia and industry, support training and knowledge exchange, and promote high-quality, data-driven corrosion research alongside with novel experimental methods and data treatment strategies.

They warmly invite colleagues to submit abstracts to the WP 8 sessions at EUROCORR 2026 and to join activities throughout the year – helping to shape the next generation of reliable, comparable, and data-enhanced corrosion testing methods.

[Click here](#) for more information.



19th NORDIC CORROSION CONGRESS

14–16th April 2026 Stockholm, Sweden

Since 1954, the Nordic Corrosion Congress has brought together researchers from all Nordic countries to connect, share ideas, and present the latest advancements in the field of corrosion. Following the successful 18th NCC meeting in Turku Finland in 2022, we are excited to host the 19th NCC in Stockholm, Sweden. The congress is organized jointly by Jernkontoret, KTH Royal Institute of Technology, RISE and Swerim.

Over the course of three days, the 19th NCC will explore the latest developments in corrosion research, covering a wide range of industrial applications and technological areas. The event will kick off with a visit to KTH Reactor Hall on the first evening followed by two days of scientific presentations. Topics will include fundamental and applied corrosion research, innovative testing methodologies, material design, and corrosion prevention strategies, among many others.

CONGRESS TOPICS

- Corrosion Mechanisms, Methods, and Modelling
- Environment Sensitive Fracture
- Techniques for Monitoring and Testing
- Advanced Analysis Techniques for Corrosion Investigations
- Marine Corrosion
- Corrosion of Steel in Concrete
- Atmospheric Corrosion
- Water and Building Installations
- Corrosion in the Energy Sector
- Durable Materials for Harsh Environments
- Corrosion and Reliability of Electronics and Micromechanics
- Automotive Corrosion
- Biomedical Applications
- Microbially Influenced Corrosion
- Tribocorrosion
- Protective Coatings, Polymers and Advanced Materials
- Additive Manufactured Metals and Corrosion
- Environmental and Health Impacts of Corrosion

First announcement and call for papers

Abstract submission

Deadline 20th Dec 2025.

Max. 300 words . Calibri font 10 size 10.

Notification of acceptance

31st January 2026

Early bird registration

Deadline 7th Feb 2026

Student SEK 3,350, Regular SEK 5,600,

EFC members SEK 5,000

Registration

Deadline 14th March 2026

Student SEK 4,500, Regular SEK 7,200,

EFC members SEK 6,700

Congress venue RISE/Swerim

Isafjordsgatan 28A,

Kista, Stockholm, Sweden

E-mail

NCC2026@swerim.se

Organizing Committee

Rachel Pettersson, Jernkontoret,

Andrew Gordon, RISE, Inger Odnevall, KTH

Olivier Rod, Swerim.

Follow QR-code for further information



WP 1 announce appointment of new Chair and Co-Chair

From the start of next year, the Working Party 1 on Corrosion and Scale Inhibition will welcome a Greek duo to the helm



As of 1 January 2026, WP 1 will welcome Prof. Dr. Kostas Demadis as Chair and Dr. Iro Spinthaki as Co-Chair for the next three-year term. But first, an introduction.

New Chair

Prof. Dr. Kostas Demadis was born in Komotini (Thrace, northern Greece) in 1967. He received his bachelor's degree from the University of Athens, Greece in 1990 and his Ph.D. in Chemistry from the University of Michigan, MI, USA in 1995. He then moved to the University of North Carolina, Chapel Hill (UNC) for a post-doc. In 1998, he was hired by the (then) Nalco Chemical Company (Naperville, IL, USA) as a Senior Chemist in their Research & Development Division.

In 2003 Kostas started his appointment as Assistant Professor in the Department of Chemistry, University of Crete, in his homeland Greece. He created the Crystal Engineering, Growth & Design Laboratory. Kostas is currently Professor of Chemistry.

Kostas' research embraces a number of projects. These include water treatment issues (mineral scale inhibition, corrosion control, metal ion absorption), phosphonate and metal phosphonate chemistry (synthesis, characterization and applications of phosphonate molecules and metal phosphonate-based materials), functional hybrid materials, silica chemistry (modelling of biosilicification mechanisms), controlled release of active pharmaceutical ingredients (in particular phosphonate-based drugs), "green" chemical technology, and the chemistry of (hydro) gels.

Kostas has published over 220 papers in peer reviewed international journals, nine books, 24 chapters in books, and is the inventor of two patents. He has delivered over 70 invited talks, over 180 conference presentations, and he has also served as a reviewer for 133 international journals, as well as for scientific/technical books and monographs. [Click here](#) for further information. He has been participating at EUROCORR conferences since 2005.

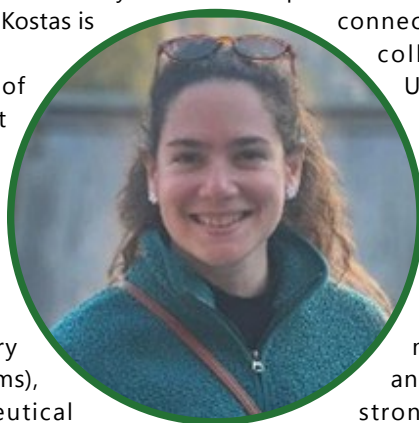

New Co-Chair

Dr. Iro Spinthaki was born in Heraklion (Crete, Greece) in 1992. She received her bachelor's degree from the University of Crete, Greece in 2014 and her Ph.D. in Chemistry from the same university in 2020, under the supervision of Prof. Dr. Kostas Demadis in the field of Inorganic Chemistry. She then moved to Viersen (NRW, Germany), where she is since working in the R&D department of Kurita Europe GmbH as a Geothermal and Screening Applications Innovation Manager.

During her professional development, Iro is responsible for the Data base and Screening / raw material efficiency evaluation procedures of the company and managed a > 30 % increase in SOP. In parallel, as the geothermal expert of the Innovations team, she has been responsible for several R&D projects including crude oil mitigation and Inorganic Scale Inhibition & Stabilisation, as well as coordinated international research initiatives, including a three-month project in Tokyo.

Iro's research interests include geothermal scale and corrosion mitigation, valuable mineral extraction and experimental set-up development. Part of her responsibilities includes the maintenance of strong connections with academia by continuing collaborations with universities (eg. University of Crete) and by taking part in fellowships such as Marie Curie, through which she will be responsible for the industrial part co-supervision of a PhD candidate in 2026-2029.

Iro has gained more than five years of R&D leadership experience and proven expertise in geothermal scaling mitigation, international collaboration, and product development, as well as a strong track record of publications and industrial achievements. [Click here](#) for more information. She has been participating at EUROCORR conferences since 2016.

The new leadership of WP 1 will uphold the high scientific standards set by the departing Chair/co-Chair, while exploring new innovative ways to increase the visibility of WP1 to EFC members and to the global corrosion/scale scientific community. The area of corrosion and scale inhibition is an important component of EFC activities, which deserves further attention and scientific/technical rigor.

[Click here](#) to visit the WP 1 website.

WP 23 Best Paper Presentation Award for Junior Researchers

The Working Party 23 ZESTRON Best Paper Presentation Award for Junior Researchers was awarded to Florian Georges (in his absence) at EUROCORR in Stavanger



Photography by Kristina Maria LaGahno Erland

Markus Meier (left) and Rajan Ambat, Chair of the Working Party 23, on the stage at EUROCORR in Stavanger announcing the award winner

Florian Georges (INSA Lyon, France) was honoured in absence as the winner of the Working Party 23 ZESTRON Best Paper Presentation Award for Junior Researchers at the closing session of EUROCORR 2025 in Stavanger, Norway.

Chair of the Working Party 23 on Corrosion Reliability of Electronics, Rajan Ambat and Dr. Markus Meier (Zestron) presented the certificate to the audience for the presentation, *Study of Halide Contamination on the Corrosion Behaviour of Materials for Microelectronic*.

Initiated by Rajan Ambat, the award is aimed at PhD and postdoctoral students, with the winner receiving a certificate and a cash prize of €500. The certificate will be handed over to Florian Georges at a suitable occasion.

About Zestron

For over 30 years, ZESTRON has been supporting its customers in making manufacturing processes more robust, increasing product reliability, and maximizing yield – for both assembled PCBs and Power Electronics.

ZESTRON are experts in the field of humidity robustness. They identify root causes of failures in assembled PCBs and develop effective corrective actions, often in relation to coating processes. For over ten years, they have been supporting companies seeking to reduce or eliminate cleaning processes. [Click here](#) to find out more.



Task Force crowns early career corrosionist at EUROCORR

Stefan Reinelt from the University of Freiburg, IMTEK, Germany was given the Early Career Best Presentation Award 2025 at EUROCORR this year



The Task Force Chair, Dr. Patrik Schmutz, presents the early career award to Stefan Reinelt for his presentation in Stavanger in September

The EFC Task Force on Corrosion of Medical Implants and Devices presented the first Early Career Best Presentation Award 2025 to Stefan Reinelt, University of Freiburg, IMTEK, Germany. Sponsored by Straumann Group, the inaugural prize was presented at EUROCORR 2025 in Stavanger by a panel of TF board members and external experts.

Mr Reinelt was recognised for his work on *The road from in vitro to in vivo corrosion monitoring of cochlear implant electrodes* and his excellent presentation skills. The jury appreciated the originality and quality of his work on platinum degradation – an emerging topic that aligns closely with the TF's objectives of identifying previously unexplored biocorrosion mechanisms.

Stefan Reinelt Project Summary

The cochlear implant (CI) is clinically the most successful neuroprosthesis, restoring hearing by electrically stimulating the auditory nerve within the cochlea. Understanding the mechanisms underlying platinum electrode corrosion during neural stimulation is crucial for ensuring long-term implant reliability. Reinelt and his team investigated how amplitude and the presence of specific electrolyte substances, including oxygen, proteins, chloride ions, and hydrogen peroxide, affect platinum corrosion in a controlled in vitro environment. Because in vitro insights must ultimately translate to in vivo conditions, Reinelt evaluated and refined different electrochemical methods, including cyclic voltammetry, chronoamperometry,

and active potentiometry. They then demonstrated their feasibility in an animal model of CI-supplied rats, paving the way for more accurate in vivo corrosion monitoring.

Advancing Medical Material Integrity

The Task Force on Corrosion of Medical Implants and Devices was officially established in 2022. It was created in response to the still limited understanding of how medical materials interact with biological matter, and to the growing number of failure reports showing that the resulting risk to material stability and function can be significantly underestimated.

Current understanding of the material-biology interactions shows that macroscopic manifestations of implant/medical-device failure, such as fractures or the release of wear particles, are already documented. However, the underlying processes that lead to the formation of micro- and nanoscale corrosion products, ionic leaching, and their consequences remain poorly understood. The Task Force aims to elucidate these 'invisible' processes to improve the prediction of biocorrosion and ultimately prevent implant and medical-device failure.

[Click here](#) to learn more about the Task Force.

About Straumann Group

The Straumann Group (SIX: STMN) is a global leader in tooth replacement and orthodontic solutions that restore smiles and confidence. Headquartered in Basel, Switzerland, the Group currently employs close to 12,000 people worldwide.

EFC Board Member awarded prestigious ICorr prize

The Institute of Corrosion's U R Evans Award has been presented to Herman Terryn, who receives an engraved sword and an Honorary Life Fellowship of the Institute

Prof Herman Terryn (part-time Professor at Vrije Universiteit Brussel, Belgium) has been awarded the Institute of Corrosion's U R Evans Award, which was presented at the Corrosion Science Symposium this year.

Prof. Terryn is a leading figure in materials science and corrosion technology, who was recently appointed as a member of the EFC Board and was awarded the European Corrosion Medal in 2014. He earned his PhD in Applied Sciences from the Vrije Universiteit Brussel (VUB) in 1987, following degrees in Chemistry (1981) and Metallurgy (1984) from the same institution. Now retired, Prof. Terryn is a part-time professor at VUB, where he held a position as professor since 2005, and a former part-time professor at the Delft University of Technology and the Université Libre de Bruxelles.

The U R Evans Award is the premier scientific award of the Institute of Corrosion and was first awarded in 1976 to honour outstanding international achievements in pure or applied corrosion science. The recipient is presented with an engraved sword at the annual Corrosion Science Symposium and they will also receive an Honorary Life Fellowship of the Institute.

Focusing his research on corrosion protection, leveraging local electrochemistry, in situ surface analysis, and modelling, Prof. Terryn has investigated various surface treatments and coatings to enhance the corrosion resistance of metals, including the conversion of aluminium and magnesium surfaces using electrochemical and surface analytical techniques. He employs advanced electrochemical methods and in situ surface analysis to study corrosion mechanisms at the micro- and nanoscale to better understand localised corrosion phenomena and develop effective protective measures.

His research involves modelling corrosion processes to predict the long-term behaviour of materials in different environments, utilising machine learning techniques to forecast atmospheric corrosion damage. Through the prestigious Methusalem project (2011-2023), he designed and predicted nanostructured metal surfaces, with the aim to develop innovative materials with enhanced durability and performance. He also participates in numerous collaborative projects, like the DurAMAT project, which focuses on the sustainable production and modelling of durable additive-manufactured materials.

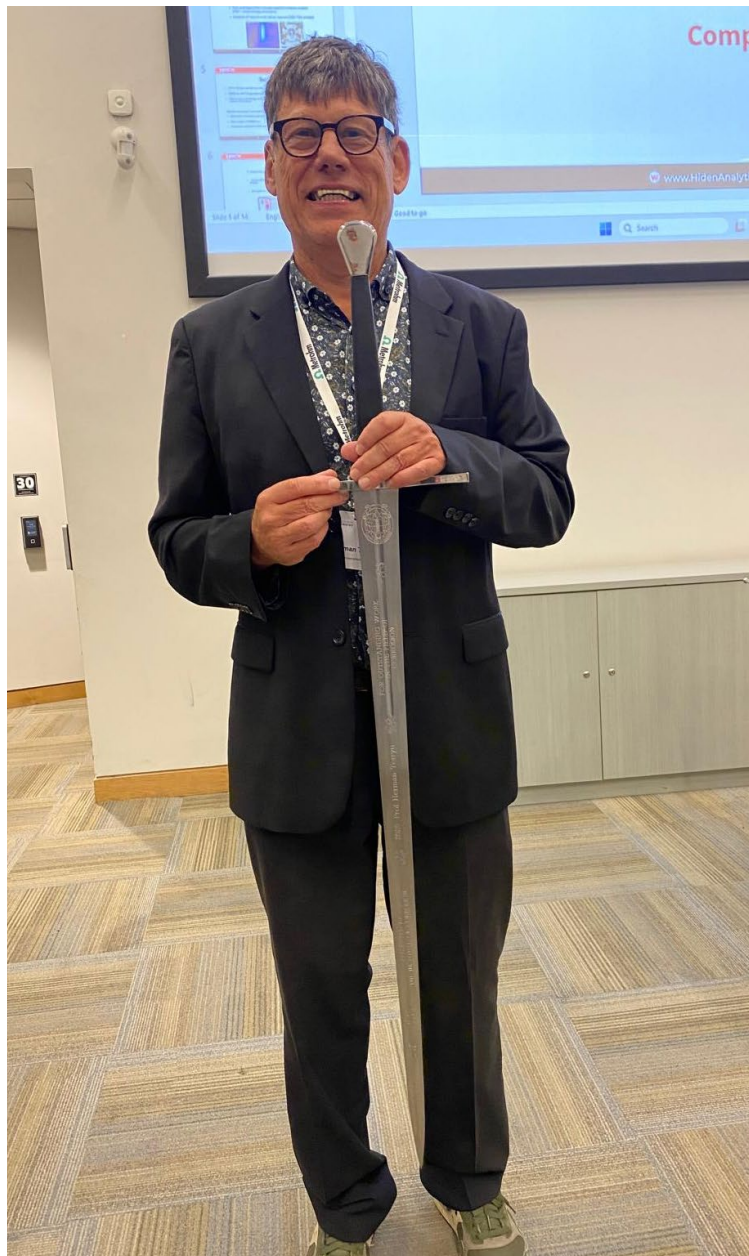

Throughout his career, Prof. Terryn has made significant contributions to the understanding of corrosion processes and the development of protective measures. His expertise has been widely recognised, as evidenced by his numerous awards and honours, including the H.H. Uhlig Corrosion Award and the Francqui Chair. Prof. Terryn continues to influence the field through his extensive research, publications, and mentorship of the next generation of scientists. [Click here](#) to read more about the U R Evans Award.

Working Party Vice-Chair named top global scientist

Working Party 9 Vice-Chair and IOM3 Corrosion Subgroup Member, Dr Shiladitya Paul recognised among the World's top 2% of scientists



Dr Shiladitya Paul has worked at TWI for close to 18 years, after earning a PhD in Materials Science from the University of Cambridge

Dr Shiladitya Paul, a member of the EFC and the IOM3 Corrosion Subgroup, has been named among the world's top 2% of scientists, according to the latest Stanford/Elsevier global ranking.

The Vice Chair of EFC Working Party 9 on Marine Corrosion and an active member of the IOM3 Corrosion Subgroup, Dr Paul is internationally recognised for his contributions to corrosion engineering, materials development, coatings technology, and materials for extreme environments.

Dr Shiladitya Paul has worked at TWI for close to 18 years, after earning a PhD in Materials Science from the University of Cambridge.

This recognition highlights IOM3 Corrosion Subgroup's sustained impact, leadership, and commitment to advancing corrosion science and engineering within the global materials community.

Corrosion Fundamentals

The IOM3 Training Academy has announced that it will be working with Dr Clayton Thomas to offer a one-day short course introducing the fundamentals of corrosion and how it can be prevented.

Corrosion and its prevention are issues that impact every industry. Understanding how materials will react in their service environment is a crucial aspect of materials selection and appreciating how potential corrosion

problems can be mitigated is an important part of the design process.

The knowledge gained from the course will enhance discussions between customers and suppliers and will assist engineers and designers when specifying materials.

This course is suitable for anyone working in engineering, production and design and who manufacture or supply engineering components. This includes buyers and salespeople. It will also be a useful introduction to the subject for new starters and graduate engineers.

The course will be run as a one day virtual session held from 09.30 to 16.30, covering basic corrosion, corrosion resistant alloys, and non-ferrous materials

IOM3 members receive a 20% discount on this course, with a preferential fee of £472. Plus, a limited number of highly discounted places are available for undergraduate, postgraduate, apprentice and Associate (AIMMM) members of IOM3 at rate of £118.

This course is one of nine in the IOM3 Metallurgy in Practice suite.

If you attend this and two of the other courses in the series, you will receive an IOM3 Certificate in Metallurgy in Practice.

And, if you attend this and five of the other courses in the series, you will receive the IOM3 Diploma in Metallurgy in Practice.

[Click here](#) to find out more.

Trento hosts Summer School supported by EFC WPs

The 3rd Summer School on Multifunctional and smart coatings for corrosion protection was successfully held in Trento, Italy, from July 14 to 18 this year



The third Summer School in Trento was organised with dual daily sessions of lectures in the morning, followed by afternoon of lab activities. Keep an eye on EFC social channels for news of the 2026 edition

The 3rd Summer School on *Multifunctional and smart coatings for corrosion protection* in Trento, Italy was organised within the framework of EFC activities and received valuable support from the Working Party 14 on Coatings and Working Party 22 on Corrosion Control in Aerospace. The Department of Industrial Engineering, University of Trento hosted the third edition, which was co-organised by an international consortium of the University of Mons (Belgium), the Universidad Complutense de Madrid (Spain), the Helmholtz-Zentrum Hereon & Kiel University (Germany), and the University of Aveiro (Portugal).

The Summer School offered an intensive and hands-on learning experience in the cutting-edge field of multifunctional and smart protective materials. The core vision of the organising committee was realised by fostering a highly productive and engaging educational environment, maintained with a number of motivated participants. The pedagogical approach effectively balanced comprehensive frontal lectures, which established the theoretical foundation, with dedicated hands-on laboratory activities, allowing for the immediate practical application of the concepts discussed.

A crucial component of the school was the close, direct contact achieved with senior scientists and leading experts in the field. The school fostered a friendly and informal setting for in-depth discussion and personalised mentoring, successfully strengthening professional

networking among attendees. Structurally, the school was organised around a dual daily schedule, with morning sessions dedicated entirely to lectures, covering topics from corrosion science fundamentals to the latest innovations in smart, self-healing, and environmentally sensing coating technologies, while afternoon sessions focused exclusively on lab activities, where participants engaged in synthesis, coating application, and the use of advanced electrochemical techniques, ensuring theory was immediately reinforced by practical experience.

A distinguished lineup of professors and experts delivered lectures covering diverse and cutting-edge aspects of corrosion protection and smart coatings: Marjorie Olivier (Surface Conversion Coatings), Jesús Manuel Vega Vega (Anodizing and PEO), João Tedim (Smart Coatings), Mikhail Zheludkevich (Electrochemical Impedance Spectroscopy), Juan José Santana Rodríguez (Localised Electrochemical Techniques), Francisco Javier Rodríguez Gomez (Electrochemical Noise), Francesco di Franco (Photocurrent spectroscopy), Stefano Rossi (Metallic coatings), Caterina Zanella (Design of experiments), Fabio Bolzoni (DC techniques), Lorenzo Soldavini (Organic coatings) and Michele Fedel (Chairman).

The Summer School was complemented by social activities, including a traditional mountain-style dinner and a poster party, allowing attendees to network and connect informally.

APCE propose regulatory shake up of water sector

The EFC Member Society has suggested acting as a technical reference point for the water sector's drive towards a modern and sustainable management of infrastructures

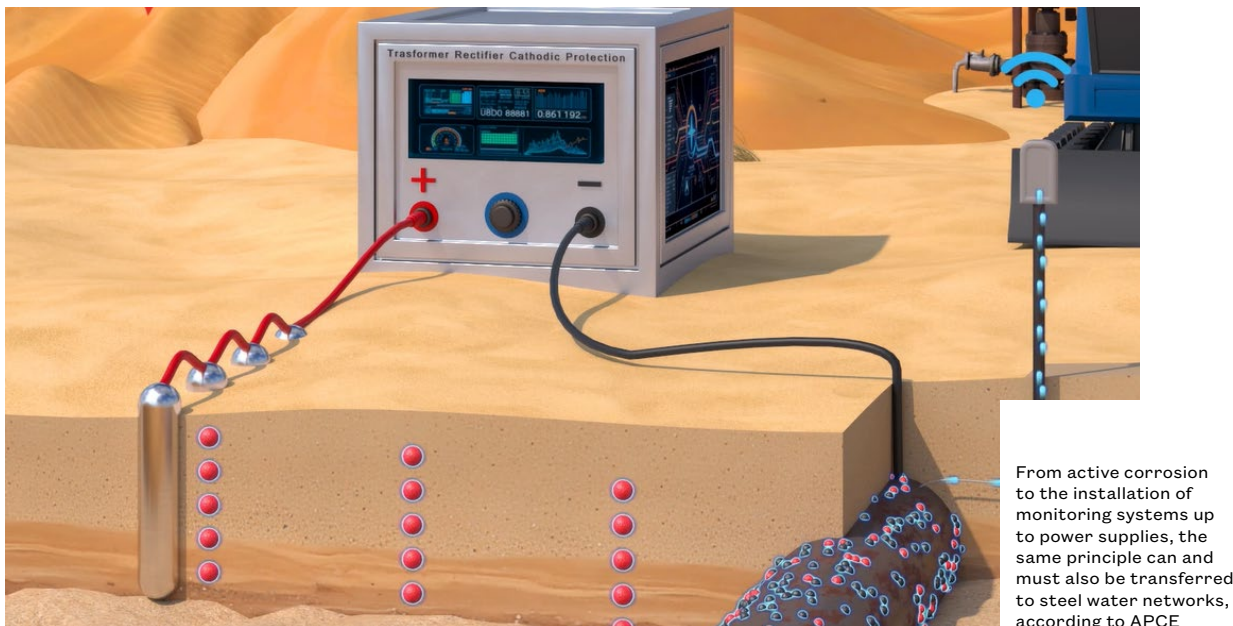

From active corrosion to the installation of monitoring systems up to power supplies, the same principle can and must also be transferred to steel water networks, according to APCE

In the gas sector, cathodic protection has been an essential technical and regulatory requirement for decades, guaranteeing the safety and durability of infrastructure. The water sector, on the other hand, does not yet have as stringent rules, and this has led to less attention on corrosion prevention over the years. The time has come to bridge this gap, adopting the consolidated principles of cathodic protection in water networks as well: an investment that protects the most precious asset, water, and significantly reduces long-term maintenance costs.

APCE has offered to be a technical reference point to accompany the water sector towards a modern and sustainable management of infrastructures, through training, regulatory support and good design practices.

Thanks to strict regulations and well-defined application standards, the gas sector has been able to count on protected and durable infrastructures, with a clear reduction in corrosive phenomena and maintenance costs. The water sector, on the other hand, has historically shown a less structured approach, with less restrictive rules and often unsystematic protection interventions.

The absence of a structured approach in applying cathodic protection in the design phase does not allow to contribute to the mitigation of corrosive phenomena that can jeopardise the integrity of structures – see ISTAT and ARERA data on Italian aqueduct networks.

It is therefore increasingly urgent that water networks adopt the same principles of prevention and protection consolidated in the gas sector when designing new water sections. Regulatory and technical uniformity is a priority to protect a strategic asset such as water and contain waste related to pipe corrosion.

Shared Principles

The technical reference standards for the cathodic protection of underground pipelines – such as UNI EN ISO 15589-1 and UNI EN 12954 – provide principles that are also valid for the water sector, adaptable to the specificities of water distribution networks.

A systematic approach to cathodic water protection would bring not only environmental benefits, but also greater resilience of networks and reduced operating costs for operators. Cathodic protection is not an expense, but an investment in the future of our water networks.

It is obviously necessary to be objective and concrete in this type of approach, APCE (Electrolytic Corrosion Protection Association) are a reference point for the management of cathodic protection applied to the gas pipeline network in Italy, would like to support the water industry using a pragmatic and not generalized approach as it would be more convenient to do: cathodic protection can be provided in the design phase of new infrastructures, then implemented and ↓

managed, to find over time a significant decrease in water losses due to corrosion of the steel in contact with the ground.

Impressed current protection, if provided for in the design phase, involves the adoption of an adequate insulating coating of the pipeline and the construction of an extremely simple direct current electrical system with extremely low construction costs compared to the cost of the work itself.

Technical Information

The insulating coating of the pipeline is essential to avoid corrosive phenomena regardless of the electrical system: on this aspect, APCE offers in its training courses in-depth technical information that is essential to ensure the integrity of the work already in the early stages of laying in the ground.

The monitoring of electrical parameters becomes a low-maintenance impact by assuming the use of remote

surveillance and, in fact, the interventions in the field are closed in extraordinary activities with low operational impact.

APCE, thanks to the experience gained in the gas sector, aims to support operators, designers, and institutions adapting good practices and regulations in the water sector, promoting training, guidelines, and field trials.

The reality of the existing water network has heterogeneous plant characteristics; it can become burdensome and impossible to envisage applying cathodic protection on the existing network by introducing a generalised technical approach; instead, it is appropriate to approach new plant implementations or the reconstruction of existing sections in a pragmatic way.

Only through a common vision and the sharing of skills between the different sectors will it be possible to guarantee a sustainable, efficient and lasting future for Italian water networks.

[Click here](#) for more information.



Thanks to experience gained in the gas sector, APCE wants to support operators and institutions adopting good practices and regulations in the water reality by promoting training, guidelines and field trials



EFC Member Society host conference in former monastery

The Italian Association for Metallurgy (AIM) symposium caps a busy period that includes the election of a new Chair and a coatings course



Flickr / Enikil Rosso

Held in a former Venetian monastery of Benedictine monks, EMCR 2025 was dominated by incredible views of Venice and a strong scientific programme, which included 60 oral presentations.

The 14th Symposium on Electrochemical Methods in Corrosion Research (EMCR 2025) was organised by Prof. Francesco Andreatta and Prof. Lorenzo Fedrizzi (University of Udine) with the patronage of the EFC and AIM.

Sponsored by the International Society of Electrochemistry (ISE), EMCR 2025 welcomed 110 participants to the island of San Servolo in the Venetian Lagoon. The programme included lectures from Prof. V. Vivier, Prof. M.E. Orazem, and Prof. A.W. Hassel, as well as 60 oral presentations and 32 posters.

EMCR 2025 consisted of one plenary and two poster sessions, an exhibition, and social events, including a welcome reception, a visit to the glass Museum in Murano, and a gala dinner, while Dr Motta who was awarded the Best Oral Presentation prize and the Best Poster prize was given to Dr Luca Gritti.

Crowded Calendar

In June 2025, Professor Marina Cabrini (University of Bergamo) was elected as the new Chair of AIM's Corrosion Technical Committee, succeeding former Chair, Professor Fabio Bolzoni from Politecnico di Milano, whom AIM would like to thank for his dedication to the committee's activities.

AIM also organised several national events, including the third module of the Coatings course, dedicated to Wet Coatings, organised by the Enzo Ferrari Engineering Department of the University of Modena and Reggio Emilia, and the webinar *Hydrogen: between current reality and future opportunities*.

New initiatives are planned for 2026, beginning with the 14th edition of the Course on Corrosion and Protection of Metallic Materials. This will be held online from January to March 2026 and will be organised into several modules. The first will cover the fundamentals of corrosion, including general aspects of monitoring, inspection, and failure analysis. The following two-day modules will focus on corrosion mechanisms, forms, and key protection strategies in natural and industrial environments, like the atmosphere, soil, water, and concrete. The final module will be dedicated to corrosion and protection of metals in various industrial sectors.

The lectures are designed to provide a solid foundation in corrosion science, followed by a comprehensive overview of significant corrosion phenomena, taking into account the typical combinations of metallic materials and environments. The programme is aimed at professionals, technicians, and engineers from various industrial sectors, as well as students and young researchers. Lecturers from academia and industry will adopt a practical, case-study-based approach, presenting and discussing real-world examples throughout the course. [Click here](#) for more information.

And following the second School on Electrochemical Techniques for the Study of Corrosion, the AIM Corrosion Technical Committee intends to promote a summer school on Environmental Assisted Cracking, scheduled for the first half of July. [Click here](#) for more information on AIM events.

MTECH 2025 welcomes 125 global participants

Hosted by the EFC Member Society, HDZaMa, the 5th International MTECH Conference on Materials – Advancing Knowledge and Collaboration attracted a global audience



The 5th International Conference on Materials (MTECH 2025) – Heat Treatment and Surface Engineering, Materials and Tribology, Corrosion and Material Testing was successfully held from 26 to 29 October 2025 at Plitvička Jezera National Park, Croatia.

The event provided an exceptional setting for the exchange of scientific ideas, professional networking, and promotion of innovation in the field of materials science.

The aim of the conference (EFC Event No. 543) was to bring together researchers, engineers, and industry experts to discuss recent developments and challenges in materials research, production, corrosion protection, and application.

MTECH 2025 attracted 125 participants, including 25 students from Croatia, Slovenia, Netherlands, France, the United States, China, Austria, Hungary, and Australia. The scientific programme included 36 oral presentations, 17 posters, four commercial lectures, and four invited talks delivered by Tea Marohnic, James Kunkle, Mato Pavlovic, and Božidar Matijevec.

Sessions and Industrial Exhibition

The sessions addressed a wide variety of topics such as materials properties and characterization, nanomaterials and nanotechnology, coatings, corrosion protection, heat treatment processes, NDT, machine learning, artificial

intelligence and quality assurance. In parallel, an industrial exhibition presented by 11 companies showcased advanced equipment and technologies for materials testing, microscopy, non-destructive testing, surface treatment, corrosion inhibition, and smart coating systems.

Busy Social Calendar

The social programme complemented the scientific sessions and encouraged informal interaction among the participants. Highlights included a bowling competition, won by the Corrosion team, and a gala dinner that fostered professional networking in a relaxed atmosphere. On the final day, participants enjoyed a guided excursion through the scenic Plitvička Jezera National Park, which provided a fitting conclusion to the event.

The conference was jointly organised by the Croatian Society for Materials and Tribology (HDMT), the Croatian Society for Heat Treatment and Surface Engineering (HDTOIP), the Croatian Center for Non-Destructive Testing (CeNI), and the Croatian Society for Materials Protection (HDZaMa).

Dissemination of Knowledge

The 5th MTECH Conference reaffirmed its reputation as a leading platform for the dissemination of knowledge, ↓



exchange of experiences, and establishment of international cooperation in materials science and engineering.

Focusing on metallic alloys, as well as contributions on other materials (such as polymers, ceramics, composites), the conference brought together a range of specialists in material science to discuss topics from both theoretical and practical viewpoints.

The organisers would like to extend their sincere gratitude to all speakers, participants, and sponsors for their contributions and support.

The next MTECH Conference will be held in two years, continuing this valuable tradition of scientific and professional excellence.

Report by Ivan Stojanovic, Croatian Society for Materials Protection



Alongside the scientific sessions on offer at MTECH 2025, a full social programme included a guided excursion through the scenic Plitvička Jezera National Park (top) and a bowling competition, won by the Corrosion team (right)

Belgian EFC Member Society honours emerging talent

Celebrating emerging talent in surface treatment, Young VOM and Vereniging ION presented the Young Professionals Awards at Future Surfaces 2025



BNL Rising Star Award 2025 winner Piet De Schepper (Alural Group) and Young VOM Voice Award 2025 winner, Stijn Tomsin (Sherwin-Williams) pose with their awards

On Wednesday 19 November 2025 at the networking evening of the Future Surfaces 2025 trade fair and conference, the Young VOM community of the Belgian association VOM and the Dutch association Vereniging ION presented the Young Professionals Awards, celebrating the young talents who are shaping the future of surface treatment in Belgium and the Netherlands.

Jointly organised by Young VOM and Vereniging ION – Vereniging Industrieel Oppervlaktebehandelend Nederland, and supported by VOM – Beyond Treatment of Surfaces as well as Young EFC – European Federation of Corrosion, these Awards carry a binational and European dimension, underlining the growing importance of innovation in an industry undergoing profound transformation.

The BNL Rising Star Award 2025 was awarded to Piet De Schepper (Alural Group, Belgium) for his project: *Closed-loop system for treatment lines – 100% reuse of process water*.

The jury appreciated the closed-loop process that saves tens of thousands of litres of water per day, as well as the remarkable example of pollution reduction provided: closed loop, zero discharge.

The Young VOM Voice Award 2025 was presented to Stijn Tomsin (Sherwin-Williams, Belgium), following a public vote, with people commenting that Stijn is an approachable person, highly professional and full of positive energy, and is always eager to learn, exchange and explain, with an open mindset.

The CRITERIA for the Rising Star Award 2025 included a focus on innovation and originality, professional excellence, impact and contribution, leadership and influence, as well as evidence and tangible results.

The Five Finalists 2025

- Piet De Schepper – Alural Group (Belgium)
- Mohamed Krid – CRM Group (Belgium)
- Jarno Smetsers – Smetsers Precision Cleaning (SPC) (Netherlands)
- Joey Wijnolst – BlastXpert (Netherlands)
- Stijn Tomsin – Sherwin-Williams (Belgium)

About Young VOM

Young VOM is the community of VOM (Belgian Association for Surface Treatment of Materials), bringing together young professionals (under 40) from the surface treatment sector in Belgium. It connects emerging talents through technical activities, company visits, networking sessions and initiatives designed to foster innovation, exchange and expertise within the industry. [Click here](#) for more information.

Young VOM Board 2025

Arne Goethals (Poedr), Tim Florizoone (Estee Coating Solutions), Vincent Peters (V-Coat), Archibald van der Elst (Lexiago), Mireille Huppertz (Stahl und Apparatebau Huppertz), Jan Verbruggen (Eco-Vision).

Advances in corrosion monitoring using thick ER-sensors

The French Corrosion Institute, a subsidiary of Swedish EFC Member Society, Research Institutes of Sweden (RISE), proposes sensor solutions for applications across environments

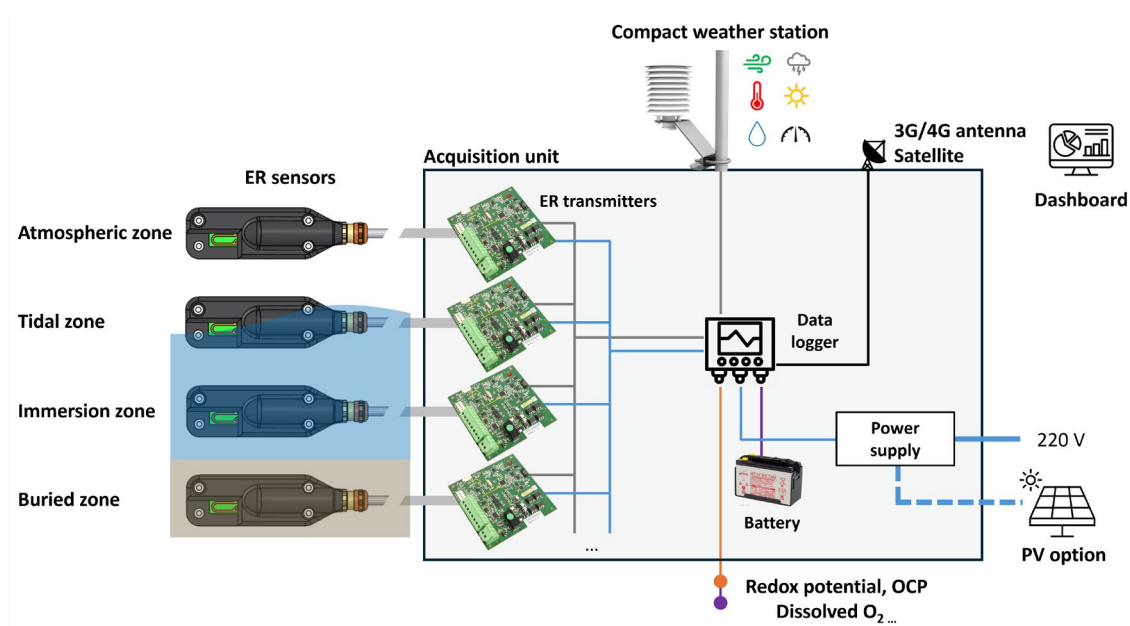

Traditional corrosion assessment methods often rely on laboratory tests and periodic field sample analysis, which provide no real-time information on the onset and propagation of corrosion.

Among the existing corrosion monitoring techniques (linear polarisation resistance, acoustic emission, quartz crystal microbalance), electrical resistance (ER) sensors are commonly used as a complementary tool during material development and qualification, offering in-situ corrosion rate data useful for the understanding of the degradation reaction dynamics.

ER-based sensors have been therefore extensively used under various conditions, including accelerated corrosion tests, atmospheric field exposures or in immersed and buried conditions.

Addressing Limitations

However, conventional ER sensors are typically made from thin model materials (low carbon steel, pure zinc or copper) in the range of tens to hundreds of microns and are therefore not fully representative of the microstructure and chemical composition of materials used in industry.

To address these limitations, the French Corrosion Institute, which is part of RISE (an EFC Member Society), recently developed new ER sensors that can be manufactured directly from industrial materials, with thicknesses ranging from 1 to more than 4mm.

Designed for atmospheric, immersed and buried environments, and suitable for applications with limited accessibility (sensors can be equipped with up to 100 metres of cable length), these ER sensors provide a more representative assessment of the monitored structure or material and offer extended service life in both harsh field and laboratory conditions.

Remote Access

Paired with a recently qualified transmitter solution compatible with the RS-485 communication protocol, multiple transmitters and ER sensors can be connected to a single data logger, which can also interface with other types of probes.

These probes enable measurement of parameters known to contribute to corrosion, such as weather conditions (wind, relative humidity, temperature, solar radiation) for atmospheric corrosion, and physic-chemical variables of water and soil (dissolved oxygen, pH, redox potential). Recorded data, when possible, can be accessed remotely from the data logger, allowing for real-time data reading and processing, e.g. using a dashboard.

[Click here](#) for more information about The French Corrosion Institute. [Click here](#) for more information about RISE. For more information contact johan.becker@institut-corroison.fr.

Affiliate Member leads research for Space Agency

CIDETEC Surface Engineering led research into the WHISFUSE project, which resulted in encouraging outcomes for the study of tin whiskers behaviour at vacuum conditions

The spontaneous growth of tin filaments – known as tin whiskers – on the surface of electronic devices represents a significant degradation phenomenon that compromises the success of The European Space Agency's space missions. WHISFUSE project has studied whiskers behaviour and conducted a deep study of structural and electrical characterisation of them.

A whisker is a metallurgical phenomenon occurring at the crystalline scale, resulting in the spontaneous growth of very thin filaments on metallic surfaces, particularly tin. While extensively studied on Earth under atmospheric conditions, little to no data existed on how these structures behave and evolve in vacuum environments, especially in an orbital setting.

Internal Stresses

The formation of whiskers is often linked to internal stresses induced by various degradation processes, including intergranular corrosion, recrystallisation, and surface reactions. These stresses can persist or even intensify under certain environmental conditions, leading to filament growth that can bridge conductive paths and cause electrical failures.

The European Space Agency (ESA) has documented several cases where commercial satellites have suffered system control processor (SCP) failures due to the growth of whiskers on electromagnetic relays. In several cases, both the main and auxiliary SCPs with which the satellites are equipped were rendered inoperative, leading to the failure of their respective aerospace endeavours.

To address this issue, a competitive call for research was launched by ESA to investigate whisker formation in vacuum conditions. CIDETEC Surface Engineering was selected to lead this effort.

During the research, a comparative analysis of the growth of whiskers under atmospheric and vacuum conditions have been conducted to determine whether there are differences in the behaviour of these filaments under such a different condition. In addition, the filaments have been melted with micro-manipulators for the purpose of electrical characterisation, thereby obtaining information on the appropriate measures to be taken to avoid subsequent malfunctions.

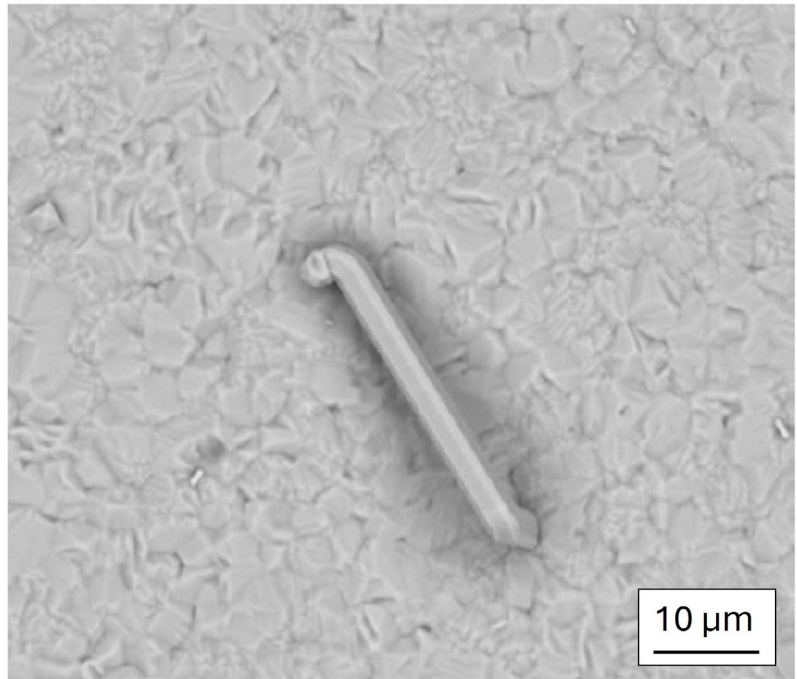

By determining the characteristics of the whisker, it will be possible to ascertain the likelihood of a short-circuit occurring and, subsequently, to implement preventative measures.

Different Characteristics

The study concluded that whiskers formed in vacuum exhibit significantly different characteristics from those formed in atmospheric conditions. Differences were observed not only in morphology but also in growth dynamics, suggesting that the absence of oxidative surface layers and other environmental factors alters the balance of internal stresses and enables alternative growth mechanisms. This leads to distinct whisker behaviour in vacuum and highlights an underexplored form of physical degradation in metal surfaces operating in space.

Apart of CIDETEC Surface Engineering experts, the project involved the participation of two leading European research organisations, namely the Budapest University of Technology and Economics (BME) and the Polish Lukaszewicz-IMiF; important references in Europe in surface engineering research in the field of whiskers.

→ This project has been funded by ESA 4000140874/23/NL/FE – Current Capacity and Effects of Vacuum of Tin Whiskers (WHISFUSE)

Emerging tech for long-term corrosion protection

EFC Affiliate Member, MONTIPOWER, outlines alternatives to Liquid-Curing Coatings and Conventional Surface Preparation



EFC Affiliate Member, MONTIPOWER highlights the benefits of visco-elastic coatings and bristle blasting as emerging technologies for long-term corrosion protection

Abstract

The long-term performance of protective coatings on pipelines and industrial assets is critical to ensure safe, reliable, and cost-effective operations. Traditional liquid-curing coating systems and abrasive blasting techniques, while well-established, are associated with limitations related to curing dependency, environmental conditions, health and safety risks, and coating degradation mechanisms.

Recent developments in visco-elastic coatings, and bristle blasting technology provide credible alternatives that are now formally recognised in international standards.

Visco-elastic coatings are included in ISO 21809-3 as Field Joint Coating (FJC) Type 13, distinguished by their amorphous polyolefin chemistry, exceptional cathodic disbondment resistance, self-healing behavior, and independence from curing reactions.

Similarly, bristle blasting will be incorporated into ISO 8501-1 with its own surface preparation class (Ma), offering a clean, anchor-profiled surface without abrasive media.

This paper presents a comparative review of these technologies, supported by independent studies, and outlines their implications for health, safety, and guaranteed 30-year performance assurance in pipeline and refinery applications.

1. Introduction

Pipeline and refinery assets are exposed to complex corrosive environments, where coating performance is the first line of defense and cathodic protection provides the secondary safeguard. Traditional coatings—fusion-bonded epoxy (FBE), multi-layer polyolefin, polyurethane, and liquid epoxies—require stringent surface preparation and curing conditions to achieve optimal adhesion. However, operational realities often include high humidity, low temperatures, inaccessibility, or health and safety constraints that limit the consistent application of liquid-curing coatings. Failures such as cathodic protection (CP) shielding, underfilm corrosion, and poor performance in disbondment tests have prompted the search for alternative coating and surface preparation technologies.

2. Visco-Elastic Coatings as Alternatives to Liquid-Curing Systems

2.1 Chemistry and Mechanism

Visco-elastic coatings (VE) are non-crystalline, fully amorphous polyolefin-based systems—typically polyisobutylene (PIB) or similar polymers—that adhere through van der Waals forces rather than chemical curing. They remain permanently flexible, with a glass transition temperature (T_g) below $-60\text{ }^\circ\text{C}$, ensuring resistance to embrittlement. Unlike curing coatings, VE materials do not cross-link or harden. They exhibit inherent self-healing of



minor damages due to molecular mobility and demonstrate high dielectric strength.

2.2 Standardisation and Performance Criteria

The ISO 21809-3 (2016) Type 13 FJC standard codifies VE coatings with specific test requirements, including: 100-day cathodic disbondment at $T_{max} + 20\text{ }^{\circ}\text{C}$, cohesive separation mode, self-healing capacity under wrap compression, drip resistance at elevated temperature, and long-term adhesion to steel and adjacent coatings after ageing in water. Field studies confirm that VE coatings can maintain steel protection for over 30 years guaranteed, even under dynamic soil stress conditions.

3. Bristle Blasting as an Alternative to Abrasive Blasting

3.1 Principle of Operation

The Bristle Blasting operation is a rotary impact tool fitted with accelerated bristles that simultaneously remove coatings, rust, and corrosion products while generating an anchor profile. Unlike grinding or needle gunning, the bristle tips elastically rebound, recreating a sharp peak-valley surface comparable to abrasive blasting. Studies show that bristle blasting produces repeatable surface roughness over $50\text{ }\mu\text{m}$, suitable for high-performance protective coatings.

3.2 Standardisation and Classification

In the revised ISO 8501-1, bristle blasting will be classified under preparation grade Ma, parallel to the Sa (abrasive blast) classes. Comparative studies from NSRP (National Shipbuilding Research Programme), DeFelsko, confirm bristle blasting delivers anchor profiles and cleanliness levels adequate for pipeline rehabilitation and refinery repairs.

3.3 Industrial Validation

Applications include petrochemical weld repairs, where bristle blasting achieved cleanliness similar to Sa 2.5-3 and $>50\text{ }\mu\text{m}$ profiles for thermal spray aluminium (TSA), with adhesion values of $>6\text{ MPa}$. It is also uniquely suited for removing PIB-based visco-elastic coatings to create inspection windows, something traditional abrasive blasting cannot achieve without damaging steel. Moreover, the tool has proven

valuable in shipyards and refineries for localised repair, where accessibility and safety preclude the use of open blasting.

4. Comparative Assessment

When comparing VE coatings and (or combined with) bristle blasting to traditional technologies, several key differentiators emerge. VE coatings eliminate curing risks and provide self-healing properties, while bristle blasting avoids dust, abrasive logistics, and hazardous waste management. Both technologies enhance safety for applicators and reduce environmental impact.

5. Health, Safety, and Sustainability

Worker safety is significantly improved through cold-applied VE coatings, which eliminate solvent and VOC exposure. Bristle blasting reduces dust generation and removes the need for abrasive disposal. These technologies also lower energy demand by eliminating compressors and abrasive handling logistics. For applicators, the presence of defined ISO standards ensures repeatability and quality assurance, addressing one of the historical challenges of non-traditional technologies.

6. Conclusions and Recommendations

Visco-elastic coatings and bristle blasting are being standards-recognised, field-proven technologies that overcome many limitations of traditional methods. Visco-elastic coatings provide unmatched self-healing, cathodic disbondment resistance, and proven lifetimes beyond 30 years. Bristle blasting offers a safe, effective method of surface preparation and unique PIB removal capabilities. Both align with health, safety, and environmental goals while ensuring coating performance reliability.

Recommendation

Operators and contractors should incorporate VE coatings and thorough bristle blasting into project specifications, particularly where long-term performance, safety, and sustainability are priorities. Ongoing monitoring and international standardization should further reinforce adoption.

[Click here](#) to find out more.

Corrosion Mitigation of an Amine Regeneration Column

Integrated Global Services (IGS), an EFC Affiliate Member, investigates the corrosion protection of a pressure vessel

During a scheduled shutdown inspection in April 2010 at an amine facility, severe corrosion was discovered inside an Amine Regeneration Column. The internal surfaces of the lower section of the carbon steel column exhibited extensive wall loss and pitting. The inspection report detailed general corrosion below trays 21–22, with wall thickness measured between 13.1–13.5 mm and localised pitting up to 2.3 mm deep. A circumferential corrosion band approximately 470 mm wide was found around the full circumference.

Similar but shallower corrosion was also noted at trays 18–19, with a maximum depth of 1.4 mm and wall thickness between 13.2–13.8 mm.

Root Cause Analysis

The root cause of this unexpected corrosion was traced to a tube failure in the associated reboiler. This failure resulted in localised acid attack where the reboiler feed entered the column via an inlet nozzle. The operator's primary concern was determining whether the column required structural repair or full replacement, both of which would entail significant capital expenditure, extended downtime, and substantial losses. A replacement was dismissed due to long procurement lead times, while internal weld overlay repair would have required post-weld heat treatment (PWHT) and external structural support to prevent collapse during the process, with a lead time of between three and four months. These complications rendered both options unattractive.

Engineering Assessment

A third-party engineering company conducted a comprehensive Fitness-For-Service (FFS) assessment in accordance with API 579 / ASME FFS-1 (2007). Stress and buckling analyses under operating and design conditions confirmed that the vessel remained structurally sound, even in its corroded state. The minimum allowable shell thickness was calculated at 7.9 mm, with a localized minimum of 6.6 mm under the inlet nozzle. This verification allowed continued operation under close monitoring while corrosion mitigation measures were implemented.

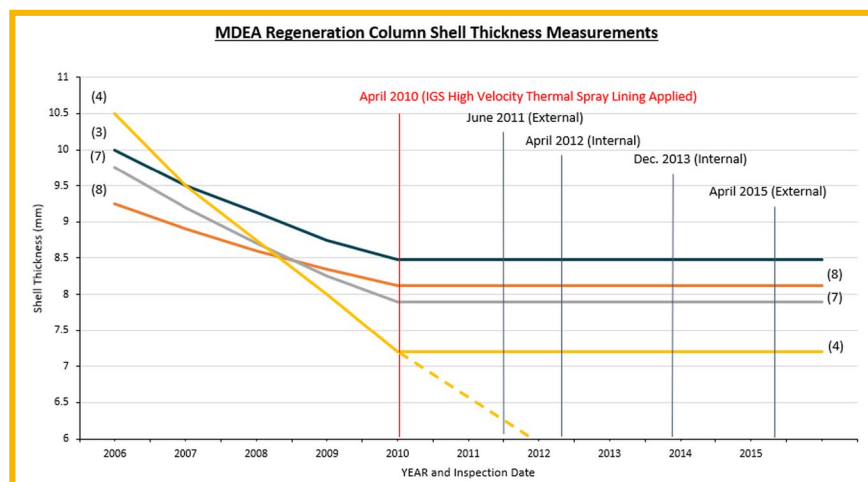

Table 1. MDEA Regeneration Column Shell Thickness Measurements

IGS HVTS Solution

To stop further metal loss and protect the column's pressure boundary, Integrated Global Services (IGS) was engaged to apply its proprietary HVTS (High Velocity Thermal Spray) internal cladding system. The solution forms a dense, corrosion-resistant barrier without generating heat-affected zones (HAZ) or requiring PWHT, allowing in-situ restoration and protection of critical process equipment with minimal downtime. Having personnel and equipment already mobilised in-country, IGS was able to respond immediately. Following inspection of the corroded areas, the internal surfaces were prepared and treated using the HVTS process to establish a durable, corrosion-resistant barrier. The cladding was applied to specification and verified to ensure full protection of the column's pressure boundary.

Results and Performance

The HVTS cladding was completed, inspected, and the trays reinstalled before the column was sealed in mid-May 2010. Subsequent inspections confirmed the cladding's integrity and the absence of further metal loss (see Table 1). After two years of stable operation and no detectable reduction in wall thickness, the operator cancelled the replacement order for the new column. The column remained in service until the end of 2015, when it was decommissioned as part of a process upgrade to increase production capacity.

The use of HVTS internal cladding system in 2010 prevented a costly structural replacement and avoided an extended unplanned shutdown, yielding estimated savings of approx. \$40 million through avoided capital costs and minimised production interruption. [Click here](#) to find out more.



Affiliate Member presents technical case study

EFC Affiliate Member, 3X Engineering investigate High-Performance and Long-Term Composite Repair of Corroded Gas Pipeline

This paper presents a technical overview of a composite repair intervention performed in July 2025 on a 6" diameter onshore gas pipeline in Europe. The repair targeted an area of external corrosion that had developed at the location of a prior temporary intervention. A composite reinforcement system was applied in accordance with international standards to restore the mechanical integrity of the pipeline and extend its operational life.

Introduction

A previously repaired section of a 6" carbon steel gas pipeline by another contractor showed signs of external corrosion and degradation. The initial repair, executed as a temporary measure, lacked conformity with established engineering standards and did not involve any structural calculations. As a result, a permanent solution was required to mitigate the risk of failure and ensure long-term asset integrity.

Scope of Work

The objective was to apply a composite reinforcement system capable of restoring the pipeline's pressure containment capacity and mechanical strength, in compliance with ISO 24.817. The repair process was divided

into multiple stages involving surface preparation, application of a bi-component epoxy resin, composite wrapping and final protective measures.

Surface Preparation

A critical step in achieving successful composite adhesion involved preparing the surface to the appropriate cleanliness and roughness levels:

- Hygrometry testing was conducted to verify environmental suitability for composite application.
- The pipe surface was prepared using a surface blasting tool, achieving a surface cleanliness level equivalent to St3/SA 2.5 and a roughness of 76.2 μm (Rz), confirmed by calibrated roughness testing.
- The surface was degreased using acetone to remove any residual contaminants prior to resin application.

Composite Wrapping Procedure

The reinforcement process was implemented as follows:

- Resin Application

A primer layer of bi-component epoxy resin was applied to ensure chemical adhesion between the substrate and the composite material.

→ Composite Wrapping

Four layers of Kevlar tape impregnated with epoxy resin were circumferentially wrapped around the defect zone. Each layer was applied under tension to maximize compaction and eliminate voids.

→ Finalisation

A final coat of resin was applied over the composite layers. An identification plate was installed on the repaired area to ensure full traceability and a UV-resistant topcoat was recommended to provide protection against environmental degradation.

Results and Performance Evaluation

The composite repair system (below) restored the structural integrity of the pipeline and enabled continued operation

without shutdown. Engineering assessments estimated an extended service lifespan of 20 years for the reinforced section. The repair provided a non-intrusive, pressure-approved and cost-effective alternative to full section replacement, with minimal operational disruption.

Conclusion

This case study highlights the efficiency of composite repair systems as a long-term structural rehabilitation solution for corroded pipelines. The successful application, performed in accordance with international standards, demonstrates the efficiency of composite technologies for critical pipeline repairs, especially in situations requiring swift implementation and minimal operational interruption.

[Click here](#) to find out more.



ADVERTISE IN THE EFC NEWSLETTER AND SPREAD YOUR MESSAGE ACROSS EUROPE

The EFC Newsletter is pleased to announce that it is welcoming advertising and enquiries. If you want to be involved, then email the address below.

e-mail COO@EFCWEB.ORG to find out more



EFC Board of Administrators 2026 to 2028 selected

The EFC welcomes its newly elected members of the Board of Administrators for the next three-year term of office, starting on 1 January 2026

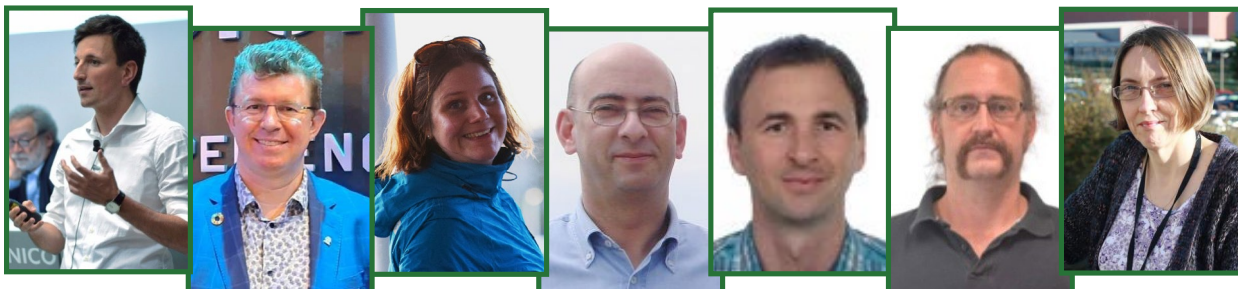

The Board Members selected are:

- **Prof. Michele FEDEL** - AIM (Italy)
- **Dr. Torben LUND SKOVHUS** - TV (Denmark)
- **Dr. Noémie OTT** - SGO-SST (Switzerland)
- **Assoc. Prof. João C. SALVADOR SANTOS FERNANDES** - SPM (Portugal)
- **Dr. Ivan STOJANOVIC** - HDZAMA (Croatia)
- **Assoc. Prof. Jan STOULIL** - AKI (Czech Republic)
- **Patricia LIDDICOTT** - the newly appointed representative of the EFC General Secretariat in the UK



They are joining the re-elected Board Members:

- **Assoc. Prof. Yaiza GONZALEZ-GARCIA** - ION/BvM (Netherlands)
- **Dr. Marta MOHEDANO SÁNCHEZ** - SOCIEMAT (Spain)
- **Dr. Philippe MARCUS** (CEFRACOR), who represents the EFC General Secretariat in France
- **Prof. Herman TERRYN** - the representative of the country of EFC's registration in law (Belgium)

Outgoing members of the Board of Administrators at the end of 2025 are: **Claude DURET-THUAL** (France), **Lorenzo FEDRIZZI** (Italy), **Bartłomiej GUZIK** (Poland), **Milan KOURIL** (Czech Republic), **Tomáš PROŠEK** (Past President – Czech Republic), and **Johan TIDBLAD** (Sweden).

EFC is very grateful for the hard work and the many hours of their time all members of the Board of Administrators have spent working on behalf of the Federation and would like to cordially thank them for their effort.

President: Gareth Hinds, Teddington, Middlesex, UK
Vice-President: Patrick Keil, Münster, Germany
Chief Operating Officer: Pascal Collet, Senlis, France
Science and Technology Advisory Committee (STAC)
Chair: Stefan Ritter, Villigen, Switzerland
Scientific Secretary: Roman Bender, Frankfurt/Main, Germany
Frankfurt Office: Andreas Förster / Ines Honndorf
Paris Office: Philippe Marcus / Mariana Berthet
London Office / Honorary Treasurer: Colin Church / Gareth Hinds / Julija Bugajeva
EFC Newsletter Editor: Dan Mobbs, London, UK

LEGAL NOTICE

European Federation of Corrosion (EFC)
 AISBL, Avenue des Arts 56/4C, 1000 Bruxelles, Belgium
Association No: 0425.591.656

VAT No: BE 0425.591.656
E-Mail: offices@efcweb.org.
Website: efcweb.org

CONTACT

Editor: Dan Mobbs editor@efcweb.org
E-Mail: offices@efcweb.org
Website: efcweb.org

The statements and opinions expressed in the EFC Newsletter are those of the contributors, for which the European Federation of Corrosion assumes no responsibility. Read more in the data privacy policy.



Stay up to date with EFC events 2025-2027

Make a date in your corrosion calendar for all the latest EFC events and conferences in Europe and around the world



WP14 WEBINAR

SMART ANALYSIS OF COATINGS: FROM PEO TO LOCAL PROBES AND AI TOOLS



REGISTRATION:



14 JAN 2026

10:30-12:00 CET

EFC Event No. 544

Federica Ceriani, PhD Candidate Politecnico di Milano

Working variables' effect on sealing post-treatments of coatings produced by PEO on AZ31 magnesium alloy

Dr. Sviatlana Lamaka, Helmholtz-Zentrum Hereon
Probing Coated Metal Interfaces with Local Electrochemical Methods

Dr. Leonardo B. Coelho, CTO Founder IAlto
Presenting the SVET Assistant: An AI-Powered Tool for Corrosion Research

EFC Working Party 14: Coatings



EFC WP 21 webinar: Bridging the Gap: Corrosion Science for Heritage Contexts

online, 10 December 2025, 15:00 CET (UTC +01:00)

EFC Event No. 542

Organised by the EFC Working Party on Corrosion of Archaeological and Historical Artefacts

Scope: This webinar will present the green book volume *Bridging the gap: corrosion science for heritage contexts* regarding the constraints of managing the preservation of heritage metal collections through ethics and case studies chapters. The event will take the form of a round table discussion between a specialist of the conservation-restoration field and a Physicochemical scientist expert in ancient metals.

[Click here](#) to register.

14th International Workshop on Application of Electrochemical Techniques to Organic Coatings - AETOC2026

Douro Region, Portugal, 23-26 March 2026

EFC Event No. 541

Organised by the University of Aveiro under the auspices of the EFC Working Party on Coatings. The chair and co-chair are members of the Portuguese Society of Materials, Member Society of EFC.

Scope: The AETOC workshop deals with all the topics related to developments in the application of

electrochemical techniques to the study and monitoring of organic coatings, as well as novel hybrid and composite coatings with self-healing and protective properties. The workshop has been organized every two years and took place previously in Schliffkopf (Germany, 1999), Jurata (Poland, 2001), Sintra (Portugal, 2003), Villard de Lans (France, 2005), Bayona (Spain, 2007), Grado (Italy, 2009), Mons (Belgium, 2011), Emmetten (Switzerland, 2013), Ile de Ré (France, 2015), Billerbeck (Germany, 2017) Valencia (Spain, 2019), Calavese (Italy, 2022) and Egmond aan Zee (The Netherlands, 2024).

Key dates: Abstract submission deadline: 30 November 2025; Early registration deadline: 31 December 2025

[Click here](#) to visit the website.

19th Nordic Corrosion Congress

Stockholm, Sweden, 14-16 April 2026

EFC Event No. 531

Co-organised by RISE Research Institutes of Sweden, together with Swerim and KTH. RISE is an EFC Member Society

Scope: Latest developments in corrosion research, industrial applications and technological areas. Topics include fundamental and applied corrosion research, innovative testing methodologies, material design, and corrosion prevention strategies.

Key dates: The call for papers is open. Deadline: 20 December 2025. See back page for more information.

[Click here](#) to visit the website.

Swiss Corrosion Science Day 2026

Villingen, Switzerland, 24 April 2026

EFC Event No. 539

Organised by the Swiss Corrosion Network, endorsed by the SGO-SST, Member Society of EFC

Scope: We aim to bring corrosion groups in Switzerland together for presentation, knowledge exchange, interaction and networking. We cordially invite scientists and engineers from academia and industry who are interested and/or confronted with corrosion-related issues in Switzerland to join the event.

[Click here](#) to visit the website.

4th Conference and Expo 2026 - Connecting experts, driving innovation in corrosion management

Genoa, Italy, 9-12 June 2026

EFC Event No. 534

Organised by the AMPP Italy Chapter, supported by the Italian EFC Member Societies AIM and APCE

Scope: The Conference aims to collect specialists from Europe and worldwide to discuss topics concerned with fundamental, engineering and applied aspects in the field of corrosion prevention, while the Expo will present materials, equipment and services addressing corrosion prevention systems.

[Click here](#) to visit the website.

EUROCORR 2026

Dublin, Ireland, 6-10 September 2026

EFC Event No. 510

See pages 2, 3 and 4 for more information.

8èmes Journées Protection Cathodique et Revêtements Associés

Aix-en-Provence, France, 29 September – 1 October 2026

EFC Event No. 536

Organised by CEFRACOR, Member Society of EFC

Scope: Cathodic protection : General (criteria, limitations, design and modelling, associated coatings), Applications sectors (on-land structures, marine structures, reinforced concrete structures, internal surfaces of equipment). See page 19 for more information.

[Click here](#) to visit the website.

SAVE THE DATE

Fifth International Conference on Corrosion Protection and Application, ICCPA

Chengdu, China, July 2026

Organised by Chongqing Association for Science and Technology, the EFC, and the Chinese Society for Corrosion and Protection (CSCP)

Scope: The last edition in Chongqing in May 2024 brought together more than 500 attendees mainly from China and Europe. Following its success, the organising team has announced the next edition will take place in Chengdu, China. The conference will provide a platform for researchers engaged in corrosion protection and application fields worldwide to showcase their talents for communication and cooperation among universities, research institutes, and companies, promoting domestic and international exchanges. Further details of the conference will be published in the next EFC Newsletter.

Global Corrosion Congress: Joint EUROCORR & ICC 2027

Prague, Czech Republic, 12-16 September 2027

EFC Event

The call for papers will open in October 2026.

[Click here](#) to visit the website.

EFC APPROVED COURSE 2026

Online, 5 February 2026, 09:30 – 16:30 BST

[Course: Introduction to Corrosion and its Prevention](#)

[Overview: EFC Approved Courses](#)

For full details of these and a complete listing of many other future corrosion events held in Europe and throughout the world, visit the [EFC Calendar of Events](#).

